

Your Wellness Solution Provider



Impulse (Qingdao) Health Tech Co., Ltd.

Add: No. 369 Huashan 2nd road, Jimo, Qingdao, China
Tel: 0086 532 85793158 or 0086 532 83958616
Fax: 0086 532 83958619
<https://www.impulsefitness.com>
E-mail: sales@impulsefitness.com





Your Wellness Solution Provider



Your Wellness Solution Provider



INTRODUCTION

In September 2017, Impulse (Qingdao) Health Tech Co., Ltd. did IPO successfully in Shenzhen stock market (Stock Code: 002899). It achieved breakthrough in capital market and Impulse became the first fitness equipment unit in China. It brought more financial support to R&D and manufacture of Impulse.

Our products cover both business and home user core demand. We provide innovative and high-quality indoor and outdoor products, including cardio equipment, strength equipment, functional training and rehabilitation training equipments, also with special ball field facilities and ice/snow training facilities.

The forward-looking design concept and user demand focused are the features of Impulse product development. We are committed to keep providing the desired products and services at a sincere price, and the products have been sold across more than 200 countries and regions, and created global marketing and after-sale systems.

Impulse is a leading supplier in health industry in China. A perfect product and service system has been built in the fields of fitness equipment R&D, manufacturing, marketing and sales, club operation and health management.

We believe that the trust of customers comes from our pursuit of product excellence and exploration of customer needs. Therefore, Impulse is going to continue following the concept of customer first and quality priority in order to serve our business partners, and become reliable fitness expert trusted by global customers.



CARDIO

A woman in a grey sports bra and leggings is running on a treadmill in a modern gym. The gym has a curved wooden ceiling and large windows. Other people are visible running on treadmills in the background. The treadmill has a digital display and a water bottle holder.

in impulse

CARDIO

R

R Series

CARDIO

R



RT950 TREADMILL

Impulse Touch Screen Operation System

1920x1080 resolution brings high definition TV contents meeting SMPTE (Society of Motion Picture and Television Engineers) standard.

A Quad-core 1.8Ghz processor with 2G memory provides powerful computing capability par with personal computer to make sure you gain unparalleled experience whenever interactive with treadmill, enjoy video or surfing internet.

Trainers could connect to internet by turning this treadmill into a terminal of information world. This machine would accompany with you to advancing with the era.

For club owners, cable TV (ATSC or DVB-T2/T or DVB-C or ISDB supported) and Virtual Scenery integrated in the OS would create better entertainment environment for trainers.

More fun, more renewals, more possibility to make decisions.



Well designed quick start page combine the key parameters and interfaces to the next level, as well as the most important quick-start button. Whatever users want to know necessary information, make advanced settings, or exercise directly, this page is enough.



Exercise Program and key parameters at a glance. The button layout is extremely convenient, what you see is what you get.

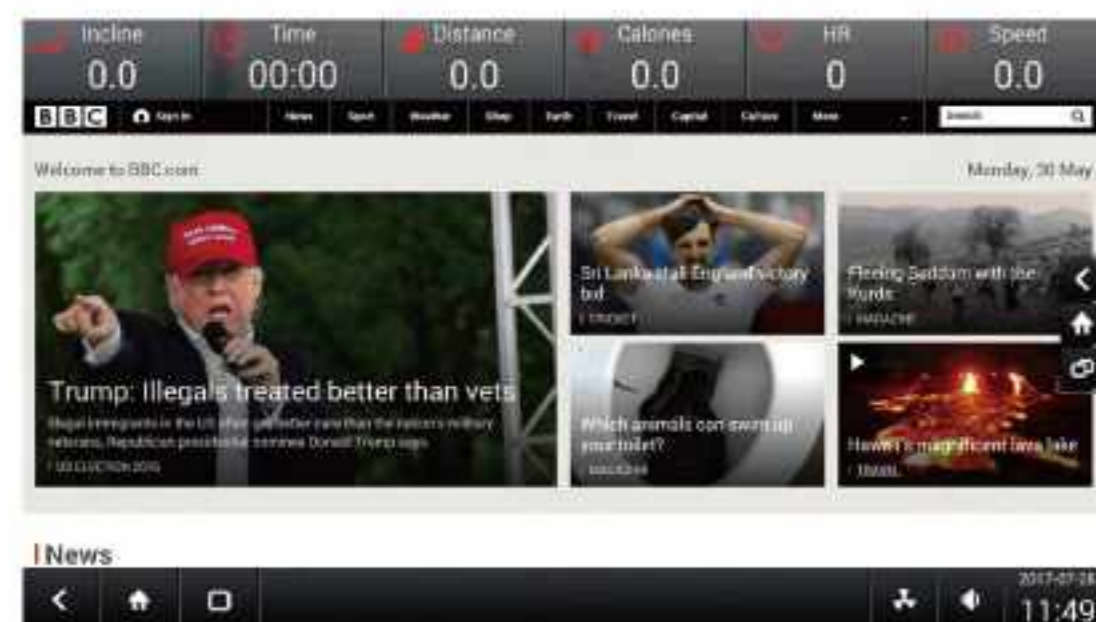

We recognize the importance of maintaining online for you, through the system comes with a browser, you will not miss any news in workout.



Providing various entertainment experiences, including video and music play. Virtual Scene provides various sites all over the world for trainers to enjoy while exercising.

Impulse RT950 VIRTUAL ACTIVE UPDATES

Create rich scenes and gives users the feel of real running experience, while the basic workouts allow you to set your own pace and enjoy the scenery.

Designed to enhance your cardie workout. Shot in beautiful locations around the world, Virtual Active transports you to iconic trails, roads, cities, and landscapes, turning indoor exercise into an outdoor adventure.

Updated Virtual Active provides more scenes such as Tibet and beautiful flats and mountains. We will explore much more virtual scenes later and keep them updated.



The beautiful forward motion, where you enjoy the scenery at your own pace, high-definition footage speeds up or slows down to match the user's pace.



The ups and downs of terrain that displayed by Virtual Scene is related to the incline of treadmill. Incline varies to match the terrain accordingly.





RT950
TREADMILL



RT750
TREADMILL

Model	RT950	RT750
Certification	CE,ETL,EN957	CE,ETL,EN957
Max User Weight	180kg/396lbs	180kg/396lbs
AC/DC	AC	AC
Power Requirement	15A	15A
Electrical Receptacle & Plug	220-240V	220-240V
Motor Power	5HP	5HP
Motor Peak Power	7.5HP	7.5HP
Speed range	0.6-25km/h (0.6-15mph)	0.6-25km/h (0.6-15mph)
Incline range	0-15%	0-15%
One Touch Buttons	3%,6%,9%,12%(Incline);3,6,9,12(Speed)	3%,6%,9%,12%(Incline);3,6,9,12(Speed)
Handle bar Control	Yes	Yes
Console Display	18.5" TFT	7 LED + Matrix 16×32
Console Readouts	Heart rate, %Heart rate, Time in zone, Average Speed, Pace, Time Elapsed, %Time Remaining, Calories, Calories/Hour, Distance, Speed, Incline, 1/4 mile or 400 meters motivational track	Heart rate, %Heart rate, Time in zone, Average Speed, Pace, Time Elapsed, %Time Remaining, Calories, Calories/Hour, Distance, Steps, Speed, Incline
Metric/English	Metric/English	Metric/English
Touch Screen	Yes	No
Entertainment (TV, WiFi etc.)	Music/TV(cable)/WiFi/Internet/Virtual Scenery	No
Programs	Cardio, Random, Fatburn, Hills, Interval, HR, 5km, Fireman test	Manual , Cardio, Interval, Burn Calories, Heart Rate, Advanced
HR Monitor	Contact&Telemetry	Contact&Telemetry
Roller Diameter	Front:88.9mm/3.5" Back:76mm/3"	Front:88.9mm/3.5" Back:76mm/3"
Deck	Reversible 1"Deck	Reversible 1"Deck
Running surface	558×1524(mm)/22"×60"	558×1524(mm)/22"×60"
Belt Thickness	3.3mm	3.3mm
Belt Brand	Habasit	Habasit
Step-up Height	245mm	245mm
Suspension System	Pulflex™ Commercial Suspension System	Pulflex™ Commercial Suspension System
Accessory Storage	IPAD/Phone Holder/Magazine Holder/2 Bottle Holders	IPAD/Phone Holder/Magazine Holder/2 Bottle Holders
USB Charger	Yes	Yes
USB Data Exchange	Yes	No
Fan	Yes (3 speed level)	Yes (3 speed level)
Multi-language Display	Yes	Yes
Gross Weight	Box1: 231.0kg/508.2lbs Box2: 35.8kg/78.8lbs	Box1: 232.2kg/510.8lbs Box2: 41.5kg/91.3lbs
Net Weight	Box1: 173.0kg/380.6lbs Box2: 30.0kg/66.0lbs"	Box1: 176.7kg/388.7lbs Box2: 30.5kg/67.1lbs"
Product Dimension	2078×950×1590(mm)/81.8"×37.4"×62.6"	2078×950×1590(mm)/81.8"×37.4"×62.6"
Packing size	Box 1: 2230×970×480(mm) 87.8"×38.2"×18.9" Box 2: 1145×1105×390(mm) 45.1"×43.5"×15.4"	Box 1: 2230×970×480(mm) 87.8"×38.2"×18.9" Box 2: 1145×1105×390(mm) 45.1"×43.5"×15.4"
40GP	40Sets	40Sets



RT930
TREADMILL



RT700
TREADMILL



RT500
TREADMILL

Model	RT930	RT700	RT500
Certification	CE,ETL,EN957	CE,ETL,EN957	CE,ETL,EN957
Max User Weight	150kg/330lbs	180kg/396lbs	150kg/330lbs
AC/DC	AC	AC	AC
Power Requirement	15A	15A	15A
Electrical Receptacle & Plug	220-240V	220-240V	220-240V
Motor Power	3HP	4HP	3HP
Motor Peak Power	4.5HP	6HP	4.5HP
Speed range	0.6-20km/h (0.6-12mph)	0.6-25km/h (0.6-15mph)	1-20km/h (0.6-12mph)
Incline range	0-15%	0-15%	0-15%
One Touch Buttons	3%,6%,9%,12%(Incline); 3,6,9,12(Speed)	2%,5%,8%,(Incline);3,6,9(Speed)	No
Handle bar Control	No	Yes	No
Console Display	11.6" TFT	7 LED + Matrix 16×40	7 LED + Matrix 16×40
Console Readouts	Heart rate, Time Elapsed, Calories, Distance, Speed, incline, 1/4 mile or 400 meters motivational track	Heart rate, Time Elapsed, Calories, Distance, Speed, incline, 1/4 mile or 400 meters motivational track	Heart rate, Time Elapsed, Calories, Distance, Speed, incline, 1/4 mile or 400 meters motivational track
Metric/English	Metric/English	Metric/English	Metric/English
Touch Screen	Yes	No	No
Entertainment (TV, WiFi etc.)	Music/TV(cable)/WiFi/Internet Virtual Scenery	No	No
Programs	Cardio, Random, Fatburn, Hills, Interval, HR, 5km, Fireman test	Manual, Cardio, Interval, Burn Calories, Heart Rate, Advanced	Manual, Cardio, Interval, Burn Calories, Heart Rate, Advanced
HR Monitor	Contact&Telemetry	Contact&Telemetry	Contact&Telemetry
Roller Diameter	Front:88.9mm/3.5" Back:76mm/3"	Front:88.9mm/3.5" Back:76mm/3"	Front:88.9mm/3.5" Back:76mm/3"
Deck	Reversable 1"Deck	Reversable 1"Deck	Reversable 1"Deck
Running surface	558×1524(mm)/22"×60"	558×1524(mm)/22"×60"	558×1524(mm)/22"×60"
Belt Thickness	2.3mm	3.3mm	2.5mm
Belt Brand	Siegling	Siegling	Siegling
Step-up Height	245mm	245mm	245mm
Suspension System	Pulflex™ Commercial Suspension System	Pulflex™ Commercial Suspension System	Pulflex™ Commercial Suspension System
Accessory Storage	Phone Holder/ 2 Bottle Holders	IPAD/Phone Holder/Magazine Holder/ 2 Bottle Holders	IPAD/Phone Holder/Magazine Holder/2 Bottle Holders
USB Charger	Yes	No	No
USB Data Exchange	Yes	No	No
Fan	Yes (3 speed level)	Yes (3 speed level)	Yes (3 speed level)
Multi-language Display	Yes	No	No
Gross Weight	Box1: 234kg/514.8lbs Box2: 34.6kg/76.1lbs	Box1: 238.0kg/523.6lbs Box2: 35.0kg/77.0lbs	Box1: 238.0kg/523.6lbs Box2: 34.5kg/75.9lbs
Net Weight	Box1: 178.0kg/391.6lbs Box2: 27.8kg/61.2lbs	Box1: 179.1kg/394.0lbs Box2: 27.5kg/60.5lbs	Box1: 179.1kg/394.0lbs Box2: 27.0kg/59.4lbs
Product Dimension	2078×875×1513(mm) 81.8"×34.4"×59.6"	2078×875×1513(mm) 81.8"×34.4"×59.6"	2080×876×1513(mm) 81.9"×34.5"×59.6"
Packing size	Box 1: 2230×970×480(mm) 87.8"×38.2"×18.9" Box 2: 975×965×280(mm) 38.4"×38.0"×11.0"	Box 1: 2230×970×480(mm) 87.8"×38.2"×18.9" Box 2: 975×965×280(mm) 38.4"×38.0"×11.0"	Box 1: 2230×970×480(mm) 87.8"×38.2"×18.9" Box 2: 975×965×280(mm) 38.4"×38.0"×11.0"
40HQ	51Sets	51Sets	51Sets
40GP	42Sets	42Sets	42Sets



RU950
UPRIGHT BIKE



RU930
UPRIGHT BIKE

Model	RU950	RU930
Certification	CE	ETL/CE/EN957
Max User Weight	180kg/396lbs	160kg/352lbs
Brake Type	Self powered hybrid brake	Self powered hybrid brake
Resistance Brake Power	450W	300W
Resistance Levels	25	20
Crank	Oversized	Standard
Pedal	Oversize dual-sided pedals with integrated straps	Single sided weighted pedal
Flywheel Weight	9kg	8kg
One Touch Buttons	No	No
Handle bar Control	3 riding positions, with contact heart rate grips and on-your-finger-tips control	3 riding positions, with contact heart rate grips
Console Display	11.6" TFT	11.6" TFT
Console Readouts	Resistance, time, distance, calories, HR, RPM	Distance, time, speed, watt, calories, RPM
Metric/English	Metric&English	Metric&English
Touch Screen	Yes	Yes
Entertainment (TV, Wifi etc.)	Music/TV(cable)/WIFI/Internet/Virtual Scenery	Music/TV(cable) /WIFI/Internet/Virtual Scenery
Programs	7	11
HR Monitor	Contact&Telemetry	Contact&telemetry
Accessory Storage	Yes	Yes
USB Charger	Yes	Yes
USB Data Exchange	Yes	Yes
Multi-language Display	Yes	Yes
Special Features	11.6" touch screen for bikes and cross-trainers Internet(wireless or wired), video streaming apps	11.6" touch screen for bikes and cross-trainers Internet (wireless or wired), video streaming apps
Gross Weight	87.3kg/192.1lbs	87.3kg/192.1lbs
Net Weight	67kg/147.4lbs	67.0kg/147.4lbs
Product Dimension	1198×602×1493 (mm)/47.2"×23.7"×58.8"	1090×660×1492(mm)/42.9"×26.0"×58.7"
Packing size	1160×405×1020(mm)/45.7"×15.9"×40.2"	1160×405×1020(mm)/45.7"×15.9"×40.2"
40HQ	116Sets	116Sets



RU700
UPRIGHT BIKE



RU500
UPRIGHT BIKE

Model	RU700	RU500
Certification	ETL/CE/EN957	ETL/CE/EN957
Max User Weight	180kg/396lbs	160kg/352lbs
Brake Type	Self Powered Hybrid Brake	Self Powered Hybrid Brake
Resistance Brake Power	450W	300W
Resistance Levels	25	20
Crank	Oversized	Standard
Pedal	Oversize dual-sided pedals with integrated straps	Single sided weighted pedal
Flywheel Weight	9kg	8kg
One Touch Buttons	No	No
Handle bar Control	3 riding positions, with contact heart rate grips and on-your-finger-tips control	3 riding positions, with contact heart rate grips
Console Display	6 Windows+Dot Matrix	7Windows+Dot Matrix
Console Readouts	Distance, time, speed, watt, calories, heart rate	Distance, time, speed, watt, calories, RPM, heart rate
Metric/English	Metric&English	Metric&English
Touch Screen	No	No
Entertainment (TV, Wifi etc.)	No	No
Programs	7	11
HR Monitor	Contact&Telemetry(polar)	Contact&Telemetry
Accessory Storage	Yes	Yes
USB Charger	No	No
USB Data Exchange	No	No
Multi-language Display	No	No
Special Features	On-your-finger-tips, Ergonomically designed handle bars, Two-sided pedals, K-O-P-S biomechanics, Easy to service	On-your-finger-tips, Ergonomically designed handle bars, Two-sided pedals, K-O-P-S biomechanics, Easy to service
Gross Weight	84.8kg/186.6lbs	81.0kg/178.2lbs
Net Weight	67.0kg/147.4lbs	68.0kg/149.6lbs
Product Dimension	1093×602×1493(mm)/ 43.0"×23.7"×58.8"	1093×602×1493(mm)/ 43.0"×23.7"×58.8"
Packing Size	1160x405×870(mm)/ 45.7"×15.9"×34.3"	1160×405×870(mm)/ 45.7"×15.9"×34.3"
40HQ	172Sets	172Sets

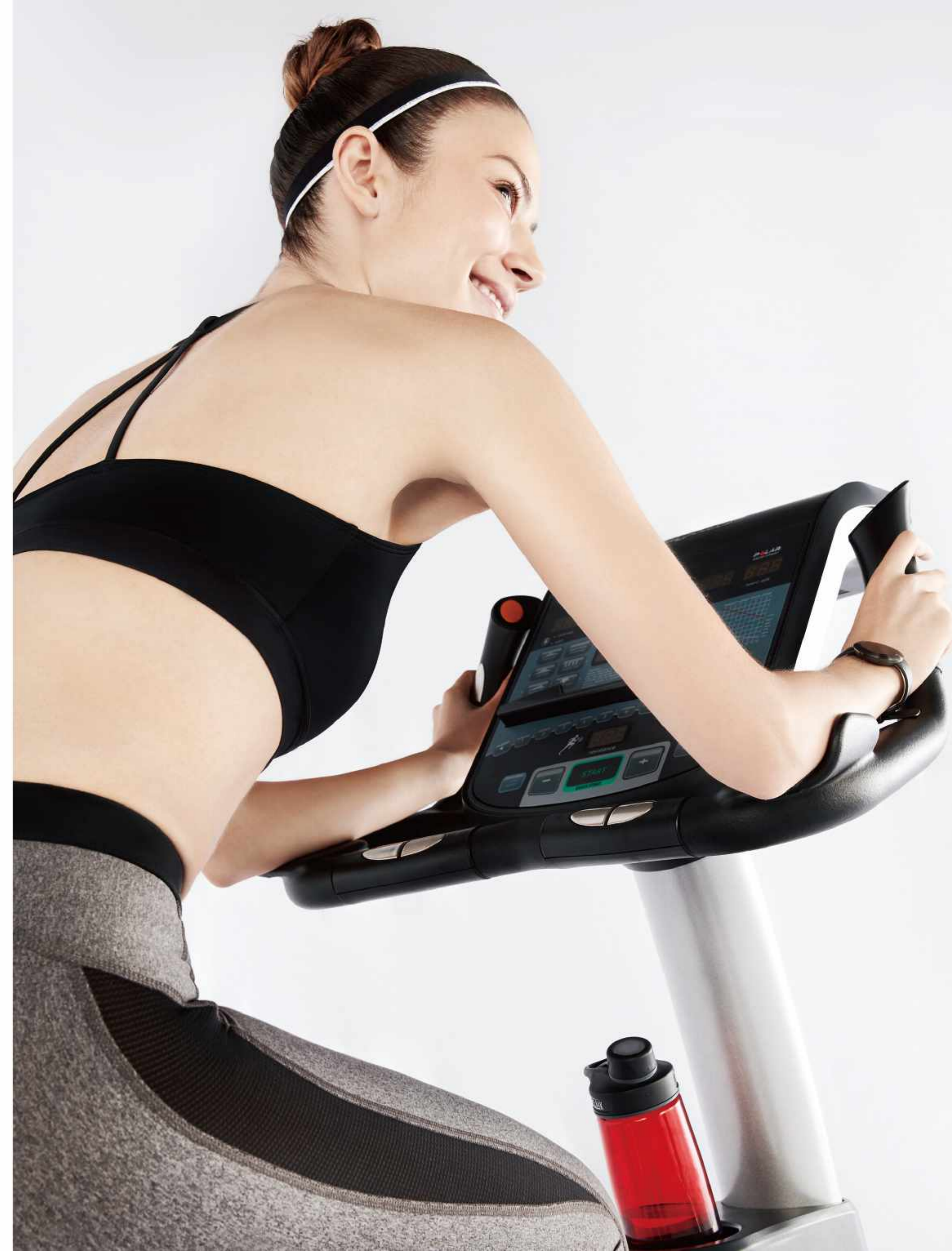

RR950
RECUMBENT BIKERR930
RECUMBENT BIKE

Model	RR950	RR930
Certification	CE	ETL/CE/EN957
Max User Weight	180kg/396lbs	160kg/352lbs
Brake Type	Self powered hybrid brake	Self Powered Hybrid Brake
Resistance Brake Power	450W	300W
Resistance Levels	25	20
Crank	Oversize	Standard
Pedal	Oversize dual-sided pedals with integrated straps	Single sided weighted pedal
Flywheel Weight	9kg	8kg
One Touch Buttons	No	No
Handle bar Control	Ergonomically designed seat-side handles with contact heart rate grips on-your-finger-tips control	Ergonomically designed seat-side handles with contact heart rate grips on-your-finger-tips control
Console Display	11.6" TFT	11.6" TFT
Console Readouts	Resistance, time, distance, calories, HR, RPM	Distance, time, speed, watt, calories, RPM
Metric/English	Metric&English	Metric&English
Touch Screen	Yes	Yes
Entertainment (TV, Wifi etc.)	Music/TV (cable) /WIFI/Internet/Virtual Scenery	Music/TV (cable) /WIFI/Internet/Virtual Scenery
Programs	7	11
HR Monitor	Contact&Telemetry	Contact&Telemetry
Accessory Storage	Yes	Yes
USB Charger	Yes	Yes
USB Data Exchange	Yes	Yes
Multi-language Display	Yes	Yes
Special Features	11.6" touch screen for bikes and cross-trainers Internet (wireless or wired), video streaming apps	11.6" touch screen for bikes and cross-trainers Internet (wireless or wired), video streaming apps
Gross Weight	107.2kg/235.8lbs	105.4kg/231.9lbs
Net Weight	83kg/182.6lbs	87.0kg/191.4lbs
Product Dimension	1700×638×1383 (mm) /69.7"×25.1"×54.4"	1650×650×1400(mm) / 65.0"×25.6"×55.1"
Packing Size	1615×435×890mm/63.6"×17.0"×35.0"	1615×435×890(mm)/ 63.6"×17.1"×35.0"
40GP	72Sets	72Sets



RR700
RECUMBENT BIKE



RR500
RECUMBENT BIKE

Model	RR700	RR500
Certification	ETL/CE/EN957	ETL/CE/EN957
Max User Weight	180kg/396lbs	160kg/352lbs
Brake Type	Self Powered Hybrid Brake	Self Powered Hybrid Brake
Resistance Brake Power	450W	300W
Resistance Levels	25	20
Crank	Oversized	Standard
Pedal	Oversize dual-sided pedals with integrated straps	Single sided weighted pedal
Flywheel Weight	9kg	9kg
One Touch Buttons	No	No
Handle bar Control	ErgoNomically designed seat-side handles with contact heart rate grips on-your-finger-tips control	ErgoNomically designed seat-side handles with contact heart rate grips on-your-finger-tips control
Console Display	6 Windows+Dot Matrix	7Windows +Dot Matrix
Console Readouts	Distance, time, speed, watt, calories, heart rate	Distance, time, speed, watt, calories, RPM, heart rate
Metric/English	Metric&English	Metric&English
Touch Screen	No	No
Entertainment (TV, Wifi etc.)	No	No
Programs	7	11
HR Monitor	Contact&Telemetry(polar)	Contact&Telemetry
Accessory Storage	Yes	Yes
USB Charger	No	No
USB Data Exchange	No	No
Multi-language Display	No	No
Special Features	On-your-finger-tips, Ergonomically designed handle bars, Two-sided pedals, K-O-P-S biomechanics, Easy to service, walk-through design	On-your-finger-tips, Ergonomically designed handle bars, Two-sided pedals, K-O-P-S biomechanics, Easy to service, walk-through design
Gross Weight	104.6kg/230.1lbs	100.7kg/222lbs
Net Weight	83.0kg/182.6lbs	79.0kg/173.8lbs
Product Dimension	1651×638×1383(mm)/ 65.0"×25.1"×54.4"	1650×650×1400(mm)/ 65.0"×25.6"×55.1"
Packing Size	1615×370×850(mm)/ 63.6"×14.6"×33.5"	1615×370×850(mm)/ 63.6"×14.6"×33.5"
40HQ	129Sets	129Sets

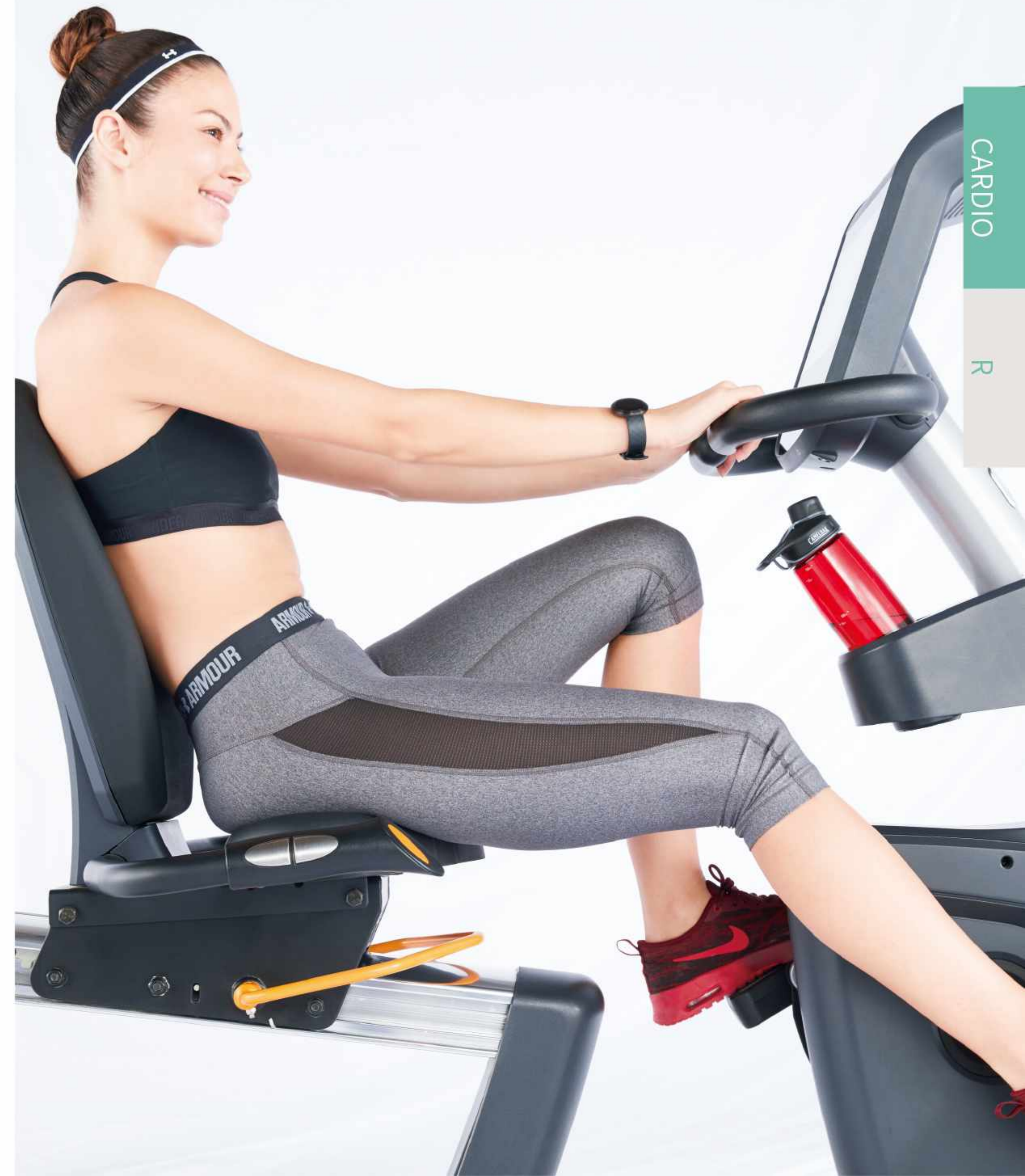

RE950
ELLIPTICALRE930
ELLIPTICAL

Model	RE950	RE930
Certification	CE	CE
Max User Weight	160kg/352lbs	160kg/352lbs
Power Supply	60W	60W
Brake Type	Self Powered Hybrid Brake	Self Powered Hybrid Brake
Resistance Brake Power	350W	350W
Resistance Levels	25	20
Electrical Receptacle & Plug	Yes	Yes
Incline range	No	No
Stride Length	533mm/21"	533mm/21"
Pedal	Pedal with cushioned gel pads	Pedal with cushioned gel pads
Pedal Spacing	1"	1"
Step-up Height	190mm/7.5"	190mm/7.5"
One Touch Buttons	No	No
Handle bar	Handle bar Control; ABS+TPU coated handlebars	PVS handlebars
Console Display	11.6" TFT	11.6" TFT
Console Readouts	Resistance, time, distance, calories, HR, RPM	Resistance, time, distance, calories, HR, RPM
Metric/English	Metric&English	Metric&English
Touch Screen	Yes	Yes
Entertainment (TV, Wifi etc.)	Music/TV (cable) /WIFI/Internet/Virtual Scenery	Music/TV (cable) /WIFI/Internet/Virtual Scenery
Programs	7	11
HR Monitor	Contact&Telemetry	Contact&Telemetry
Accessory Storage	Cup holder, Magazine Holder, Phone Holder	Cup holder, Magazine Holder, Phone Holder
USB Charger	Yes	Yes
USB Data Exchange	Yes	Yes
Multi-language Display	Yes	Yes
Special Features	11.6" touch screen for Elliptical and cross-trainers Internet (wireless or wired), video streaming apps	On-your-finger-tips, Ergonomically designed handle bars, Easy to service
Gross Weight	174.9kg/384.8lbs	174.9kg/384.8lbs
Net Weight	118.0kg/259.6lbs	118.0kg/259.6lbs
Product Dimension	2180×742×1610 (mm) / 85.8" ×29.2" ×63.4"	2179×742×1610(mm)/ 85.8" ×29.2" ×63.4"
Packing Size	2300×650×1090(mm)/ 90.6"×25.6"×42.9"	2300×650×1090(mm)/ 90.6"×25.6"×42.9"
40HQ	36Sets	36Sets

RE700
ELLIPTICALRE500
ELLIPTICAL

Model	RE700	RE500
Certification	CE,ETL,EN957	CE,ETL,EN957
Max User Weight	160kg/352lbs	160kg/352lbs
Brake Type	Self Powered Hybrid Brake	Self Powered Hybrid Brake
Resistance Brake Power	350W	350W
Resistance Levels	25	20
Electrical Receptacle & Plug	No	No
Incline range	No	No
Stride Length	533mm/21"	533mm/21"
Pedal	Pedal with cushioned gel pads	Pedal with cushioned gel pads
Pedal Spacing	1"	1"
Step-up Height	190mm/7.5"	190mm/7.5"
One Touch Buttons	No	No
Handle bar	Handle bar Control; ABS+TPU coated handlebars	PVS handlebars
Console Display	6 Windows+Dot Matrix	7 Windows+Dot Matrix
Console Readouts	Speed, Time, Calorie, RPM, Distance, Heart rate, Resistance, etc.	Speed, Time, Calorie, RPM, Distance, Heart rate, Resistance, etc.
Metric/English	Metric&English	Metric&English
Touch Screen	No	No
Entertainment (TV, Wifi etc.)	No	No
Programs	7	11
HR Monitor	Contact&Telemetry	Contact&Telemetry
Accessory Storage	Cup holder, Magazine Holder, Phone Holder	Cup holder, Magazine Holder, Phone Holder
USB Charger	No	No
USB Data Exchange	No	No
Multi-language Display	No	No
Special Features	On-your-finger-tips, Ergonomically designed handle bars, Easy to service	On-your-finger-tips, Ergonomically designed handle bars, Easy to service
Gross Weight	174.5kg/383.9lbs	175.4kg/385.9lbs
Net Weight	118.1kg/259.8bs	119.4kg/262.7lbs
Product Dimension	2179 × 742 × 1610(mm)/ 85.8" × 29.2" × 63.4"	2179 × 742 × 1610(mm)/ 85.8" × 29.2" × 63.4"
Packing Size	2220 × 650 × 1090(mm)/ 87.4" × 25.6" × 42.9"	2220 × 650 × 1095(mm)/ 87.4" × 25.6" × 43.1"
40GP	36Sets	36Sets

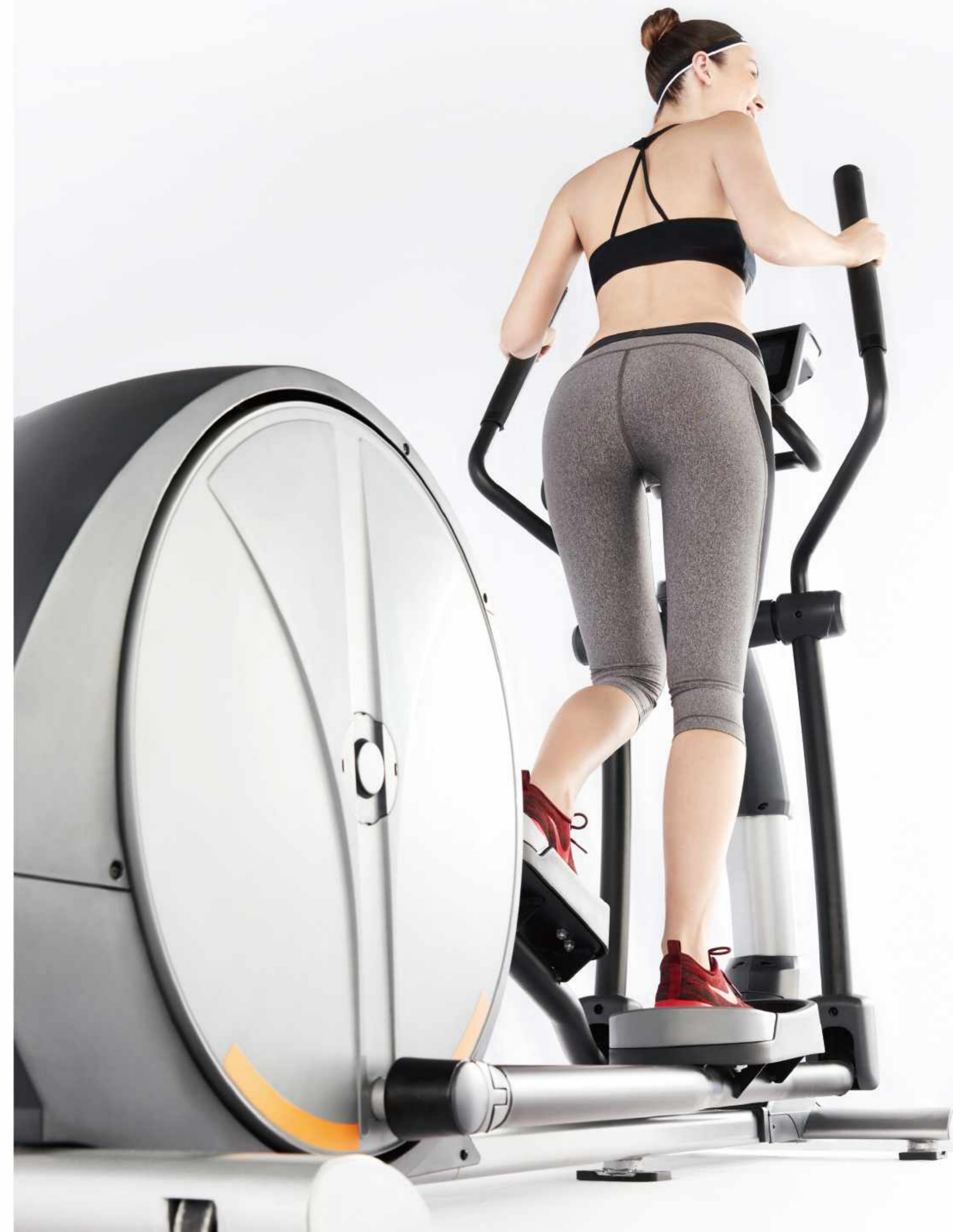

P Series



PT500
TREADMILLPT300
TREADMILLPST300
STEPPER

Model	PST300
Certification	CE
Max User Weight	150kg/330lbs
Brake Type	Self Powered Hybrid Brake
Resistance Brake Power	300W
Resistance Levels	20 Levels
Electrical Receptacle & Plug	No
Incline range	No
Stride Length	No
Pedal	Pedal with cushioned gel pads
Pedal Spacing	82mm/3.2"
Step-up Height	330mm/13"
One Touch Buttons	No
Handle bar Control	Yes
Console Display	7 LED+Matrix 16×40
Console Readouts	Distance, time, speed, watt, calories, calories/hours, mets, RPM, heart rate
Metric/English	Metric&English
Touch Screen	No
Entertainment (TV, Wifi etc.)	No
Programs	11
HR Monitor	Contact&Telemetry
Accessory Storage	Cup holder, Magazine Holder, Phone Holder
USB Charger	No
USB Data Exchange	No
Multi-language Display	No
Special Features	On-your-finger-tips, Ergonomically designed handle bars, INA clutch
Gross Weight	137.0kg/301.4lbs
Net Weight	96.0kg/211.2lbs
Product Dimension	1257×881×1646(mm)/ 49.5"×34.7"×64.8"
Packing Size	1185×910×760(mm)/ 46.7"×35.8"×29.9"
40GP	67Sets

Model	PT500	PT300
Certification	CE	CE,ETL,EN957
Max User Weight	150kg/330lbs	150kg/330lbs
AC/DC	AC	AC
Power Requirement	15A	15A
Electrical Receptacle & Plug	220-240V	220-240V
Motor Power	3HP	3HP
Motor Peak Power	4.5HP	4.5HP
Speed range	0.6-20km/h (0.6-12mph)	0.6-20km/h (0.6-12mph)
Incline range	0-15%	0-15%
One Touch Buttons	3%,6%,9%,12%(incline), 3,6,9,12(speed)	2%,4%,6%,8%,10%,12%(incline), 2,4,6,8,10,12(Speed)
Handle bar Control	No	No
Console Display	18.5" TFT	6 LED + Matrix 16×40
Console Readouts	Heart rate, Time Elapsed, Calories, Distance, Speed, incline,1/4 mile or 400 meters motivational track	Heart rate, Time Elapsed, Calories, Distance, Speed, incline, 1/4 mile or 400 meters motivational track
Metric/English	Metric&English	Metric&English
Touch Screen	Yes	No
Entertainment (TV, Wifi etc.)	Music/TV (cable) /WiFi/Internet/Virtual Scenery	No
Programs	Cardio, Random, Fatburn, Hills, Interval, HR, 5km, Firemantest.	5 Preset, 3 Targets, 2 User, 3 HR
HR Monitor	Contact&Telemetry	Contact&Telemetry
Roller Diameter	Front:88.9mm/3.5" Back:76mm/3"	Front:88.9mm/3.5" Back:76mm/3"
Deck	Reversible 1"deck	Reversible 1"deck
Running surface	545x1520(mm)/21.5"x 60"	550x1550(mm)/21.6"x 61"
Belt Thickness	2.3mm	2.5mm
Step-up Height	260mm	260mm
Suspension System	Pulflex™ Commercial Suspension System	Pulflex™ Commercial Suspension System
Accessory Storage	Phone Holder/ 2 Bottle Holders	Phone Holder/ 2 Bottle Holders
USB Charger	No	No
USB Data Exchange	No	No
Fan	Yes (3 speed level)	Yes (3 speed level)
Multi-language Display	Yes	No
Gross Weight	Box1: 225.0kg/495.0lbs Box2: 45.0kg/99.0lbs	Box1: 223.8kg/492.4lbs Box2: 39.5kg/86.9lbs
Net Weight	Box1: 171.5kg/377.3lbs Box2: 36.5kg/80.3lbs	Box1: 180.2kg/396.4lbs Box2: 30.9kg/68.0lbs
Product Dimension	2135×933×1460(mm) 84.0"×36.7"×57.5"	2130×926×1445(mm) 83.8"×36.4"×56.9"
Packing Size	Box 1: 2260×930×550(mm) 89.0"×36.6"×21.7" Box 2: 1265×1050×350(mm) 49.8"×41.3"×13.8"	Box 1: 2260×930×550(mm) 89.0"×36.6"×21.7" Box 2: 1265×1050×350(mm) 49.8"×41.3"×13.8"
40HQ	41Sets	41Sets
40GP	36Sets	36Sets

AC4000 TREADMILL



The 18.5-inch large console created by the new design language features convenient operation and entertainment functions. The 60 degrees tilted panel provides the best viewing Angle and comfortable experience.



50x185x2.5mm oversized column is adopted to ensure the stability of the console during movement, when the speed reaches 20km/h, the vibration amplitude of the motor is less than 0.003mm.



The motor cover adopts a flat design to make it more integrated with the frame of the running platform and more concise and hardcore in appearance. On this basis, the column cover is added and the lower end of the column is wrapped in the motor cover to make the column and running platform perfectly integrated.



Considering the safety of the product, the manufacturing process of the edge strip is upgraded from PVC extrusion to ABS injection molding, which increased the friction coefficient and enhanced the anti-slip performance.

Model	AC4000
Certification	CE
Max User Weight	150kg/330lbs
AC/DC	AC
Power Requirement	15A
Electrical Receptacle & Plug	220-240V
Motor Power	3HP
Speed range	1-20km/h
Incline range	0 to 15%
One Touch Buttons	3%,6%,9%(Incline);3,6,9(Speed)
Console Display	LED
Console Readouts	Time, Avg Speed, Heart Rate, Distance, Steps, Calories, Cal/Hour, Speed, Incline, 1/4 mile or 400 meters motivational track
Metric/English	Metric&English
Programs	Manual, Cardio, Heart Rate, Interval, Burn Calories, Target
HR Monitor	Contact&Telemetry
Roller Diameter	Front:88.9mm/3.5" Back:76mm/3"
Deck	Reversable 1"Deck
Running surface	545×1524(mm) / 22"× 60"
Belt Thickness	2.3mm
Step-up Height	260mm
Suspension System	Pulflex Commercial Suspension System
Accessory Storage	IPAD/Phone Holder/Magazine Holder/ 2 Bottle Holders
USB Charger	Yes
Fan	Yes (3 speed level)
Gross Weight	Box1: 231kg/508.2lbs Box2: 35.8kg/78.8lbs
Net Weight	Box1: 173kg/380.6lbs Box2: 30kg/66lbs
Product Dimension	2102×950×1592(mm) 81.7"×37.4"×62.6"
Packing size	Box 1: 2230×970×480(mm) 87.8"×38.2"×18.9" Box 2: 1145×1105×390(mm) 45"×43.5"×15.4"
40HQ	44Sets
40GP	40Sets

AC2990 TREADMILL



The 3D fixed upright can easily eliminate the abnormal sound and console shaking along with the running. At the same time, move the upright to the front can create a wide running environment and eliminate visual obstacles.



Taking full consideration of the commercial long running situation, the dustproof heat dissipation holes are designed in the console and the motor cover to dissipate heat from the electrical part and prevent the aging problem.

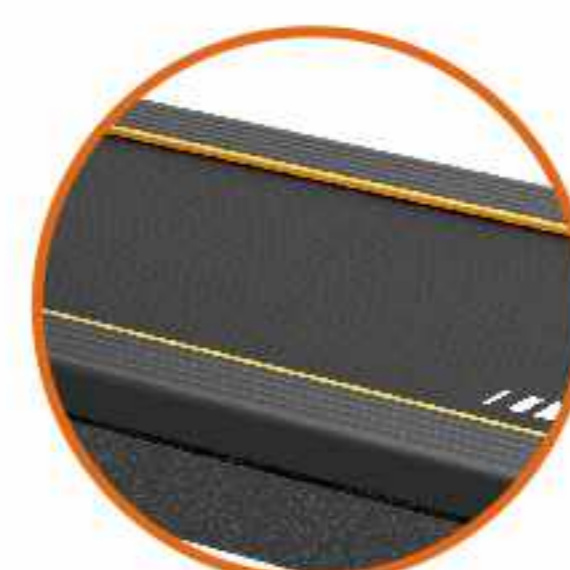

The platform structure was upgraded on the basis of AC2970 to improve the stability and safety. The replacement of a more advanced console surface material is all about enhancing the product's durability.



Ergonomic handle design; more quick buttons and a larger phone/tablet holder for a more comfortable user experience.

Model	AC2990
Max User Weight	150kg/330lbs
AC/DC	AC
Power Requirement	15A
Electrical Receptacle & Plug	220-240V
Motor Power	3HP
Motor Peak Power	4.5HP
Speed range	1-20km/h
Incline range	0 to 15%
One Touch Buttons	2%,4%,6%,8%,10%,12%(Incline);2,4,6,8,10,12(Speed)
Console Display	6 LED + Matrix 8×16
Console Readouts	Time, Avg Speed, Heart Rate, Distance, Steps, Calories, Cal/Hour, Speed, Incline.
Metric/English	Metric&English
Programs	Manual mode; Target mode: time, distance and calories; Standard mode: P1-P5; User mode: U1 and U2; Heart rate mode: HR1, HR2, HR3
HR Monitor	Contact
Roller Diameter	Front:76.5mm/3" Back:76.5mm/3"
Deck	Reversable 1"Deck
Running surface	560×1524(mm)/ 22.0"×60.0"
Belt Thickness	2.3mm
Step-up Height	250mm
Suspension System	Pulflex Commercial Suspension System
Accessory Storage	Phone Holder/ 2 Bottle Holders
Gross Weight	239.7kg/527.3lbs(TBD)
Net Weight	170.3kg/374.7lbs(TBD)
Product Dimension	2206×923×1579(mm) 86.9"×36.3"×62.2"
Packing Size	BOX1:2320×955×530(mm) 91.3"×37.6"×20.9" BOX2:1025×1015×360 40.3"×40.0"×14.1"
40HQ	44
40GP	37

* The right of specific weight to actual supply prevail.



● ECT7
TREADMILL

● ECE7
ELLIPTICAL

● ECR7
RECUMBENT BIKE

● ECU7
UPRIGHT BIKE

● ES3000
3 STACK MULTI-STATION
● ES3000 OPT
HI-LO PULLEY ATTACHMENT

● ES9030
DUAL ADJUSTABLE PULLEY
● ES7011
BENCH

ENCORE

The Complete Series

Space Solutions for Corporate Fitness

ECT7 TREADMILL



Built in bottle holders, accessories tray on both sides and display rack.



Ergonomically designed handle bars with a towel rail.



User-friendly console with keypad and scrolling LED window, multiple workout programs and unique heart rate zone programs.



Bright orange colored staddle cover trim for step-on and step-off safety.

Model	ECT7
Max User Weight	160kg/352lbs
AC/DC	AC
Power Requirement	15A
Electrical Receptacle & Plug	220-240V
Motor Power	3HP
Motor Peak Power	4.5HP
Speed range	1-20km/h (0.6-12mph)
Incline range	0 to 15%
One Touch Buttons	3%,6%,9%,12%(incline),3,6,9,12(Speed)
Handle bar Control	Yes
Console Display	6 window + dot Matrix
Console Readouts	Heart rate, Time Elapsed, Calories, Distance, Speed, incline, 1/4 mile or 400 meters motivational track
Metric/English	Metric&English
Touch Screen	No
Entertainment (TV, Wifi etc.)	No
Programs	Target, Manual, Cardio, Interval, Burn Calories, Heart Rate, 5K, Hill, Advanced
HR Monitor	Contact&Telemetry
Roller Diameter	Front:76mm/3" Back:63.8mm/2.5"
Deck	Reversable 1"deck
Running surface	508x1524(mm)/20"x 60"
Belt Thickness	2.5mm
Belt Brand	Siegling
Step-up Height	224mm
Suspension System	Pulflex™ Commercial Suspension System
Handle bar Control	Yes
Handle Folding	No
Accessory Storage	IPAD, Phone Holder, Magazine Holder, 2 Bottle Holders
USB Charger	No
USB Data Exchange	No
Fan	Yes (3 speed level)
Multi-language Display	No
Gross Weight	Box1: 183.6kg/403.9lbs Box2: 30.0kg/66.0lbs
Net Weight	Box1: 128.1kg/281.8lbs Box2: 22.1kg/48.6lbs
Product Dimension	2045 × 940 × 1455(mm)/80.5" × 37.0" × 57.3"
Packing Size	Box 1: 2215 × 850 × 475(mm) 87.2" × 33.5" × 18.7" Box 2: 1045 × 855 × 410(mm) 41.1" × 33.7" × 16.1"
40HQ	54Sets

ECE5 ELLIPTICAL



User-friendly console with keypad and scrolling LED window, multiple workout programs and unique heart rate zone programs.



Multi grip ergo handles provide users of varying heights difference workout experiences.



Ergonomically correct pedals provide the ultimate natural motion.



User-friendly mini step allows users to step on and off from the rear.



Easy to service shroud design allows for convenient maintenance.



Model	ECE5
Certification	CE
Max User Weight	150kg/330lbs
Brake Type	Self Powered Hybrid Brake
Resistance Brake Power	350W
Resistance Levels	20 Levels
Electrical Receptacle & Plug	No
Incline range	No
Stride Length	508mm/20"
Pedal	Pedal with cushioned gel pads
Pedal Spacing	75mm/2.95"
Step-up Height	250mm/9.84"
One Touch Buttons	No
Handle bar Control	Yes
Console Display	6 LED windows + dot Matrix LED
Console Readouts	Speed, Time, Calorie, RPM, Distance, Heart rate, Resistance, etc.
Metric/English	Metric&English
Touch Screen	No
Entertainment (TV, Wifi etc.)	No
Programs	8 Preset, 4 Targets, 1 User
HR Monitor	Contact&Telemetry
Accessory Storage	Cup holder, Magazine Holder, Phone Holder
USB Charger	No
USB Data Exchange	No
Multi-language Display	No
Gross Weight	162.2kg/356.8lbs
Net Weight	119.6kg/263.1lbs
Product Dimension	1849×812×1800(mm)/72.8"×31.9"×70.9"
Packing Size	1150×765×1110(mm)/45.3"×30.1"×43.7"
40HQ	60Sets

ECR7 RECUMBENT BIKE



Model	ECR7
Certification	CE
Max User Weight	150kg/330lbs
Brake Type	Self-generating
Resistance Brake Power	300W
Resistance Levels	20
Crank	Standard
Pedal	Weighted pedal with skate-style clip
Flywheel Weight	8kg
One Touch Buttons	No
Handle bar Control	Ergonomically designed seat-side handles with contact heart rate
Console Display	6 LED windows + dot Matrix LED
Console Readouts	Speed, Time, Calorie, RPM, Distance, Heart rate, Resistance, etc.
Metric/English	Metric&English
Touch Screen	No
Entertainment (TV, Wifi etc.)	No
Programs	12
HR Monitor	Contact&Telemetry
Accessory Storage	Yes
USB Charger	No
USB Data Exchange	No
Multi-language Display	No
Special Features	On-your-finger-tips, ergonomically designed handle bars, two-sided pedals, k-o-p-s biomechanics, easy to service
Gross Weight	100.7kg/ 221.5lbs
Net Weight	83.2kg/183.0lbs
Product Dimension	1670 × 634 × 1326(mm)/65.7" × 25.0" × 52.2"
Packing Size	1775 × 445 × 730(mm)/70.0" × 17.5" × 28.7"
40GP	96Sets



User-friendly console with keypad and scrolling LED window, multiple workout programs and unique heart rate zone programs.



Multiple riding grip positions are fitted with two sets of heart-rate reception, which provides users different workout experience. Bright colored fingertip controls for changing resistance for easy adjustments throughout the workout.



Dual oversized water bottle holders and mobile phone pocket conveniently located for those long bike rides.



Ergonomic single-hand seat adjustment makes easy to find the right position.



Easy to service shroud design allows for convenient maintenance.



ECU7 UPRIGHT BIKE



Model	ECU7
Certification	CE
Max User Weight	150kg/330lbs
Brake Type	Self-generating
Resistance Brake Power	300W
Resistance Levels	20
Crank	Standard
Pedal	Weighted pedal with skate-style clip
Flywheel Weight	8kg
One Touch Buttons	No
Handle bar Control	3 riding positions , with contact heart rate grips
Console Display	6 LED windows +dot Matrix LED
Console Readouts	Speed, Time, Calorie, RPM, Distance, Heart rate, Resistance, etc.
Metric/English	Metric&English
Touch Screen	No
Entertainment (TV, Wifi etc.)	No
Programs	12
HR Monitor	Contact&Telemetry
Accessory Storage	Yes
USB Charger	No
USB Data Exchange	No
Multi-language Display	No
Special Features	On-your-finger-tips, ergonomically designed handle bars, two-sided pedals, k-o-p-s biomechanics, easy to service
Gross Weight	78.5kg/172.7lbs
Net Weight	67.4kg/148.3lbs
Product Dimension	1140×635×1480(mm)/ 44.9"×25.0"×58.3"
Packing Size	1155×445×730(mm)/ 45.5"×17.5"×28.8"
40GP	156Sets

HSR007 SKI & ROW Multiple Training Machine



MARS (Magnetic & Air Resistance System) allows users to control their exertion and resistance at all time. The MARS system with 20 settings so you can change the resistance to suit your performance.



Adjustable pedals and ergonomic handle bars accommodate different users' need. The sturdy legs provide users a comfortable and stable movement.



Heart rate telemetry system helps users to monitor intensity of the workout. Your exercise data can be easily synchronized to Wahoo devices via Bluetooth. Adjustable angle of console provides users with the best viewing experience in using condition.

High intensity cords achieve the maximum strength test up to 1,000,000 times ensuring the high quality of products.



Ergonomic seat enables users to train comfortably. Light-weight aluminum and stainless steel made slide rail allows users to train intensively and provide a low maintenance.

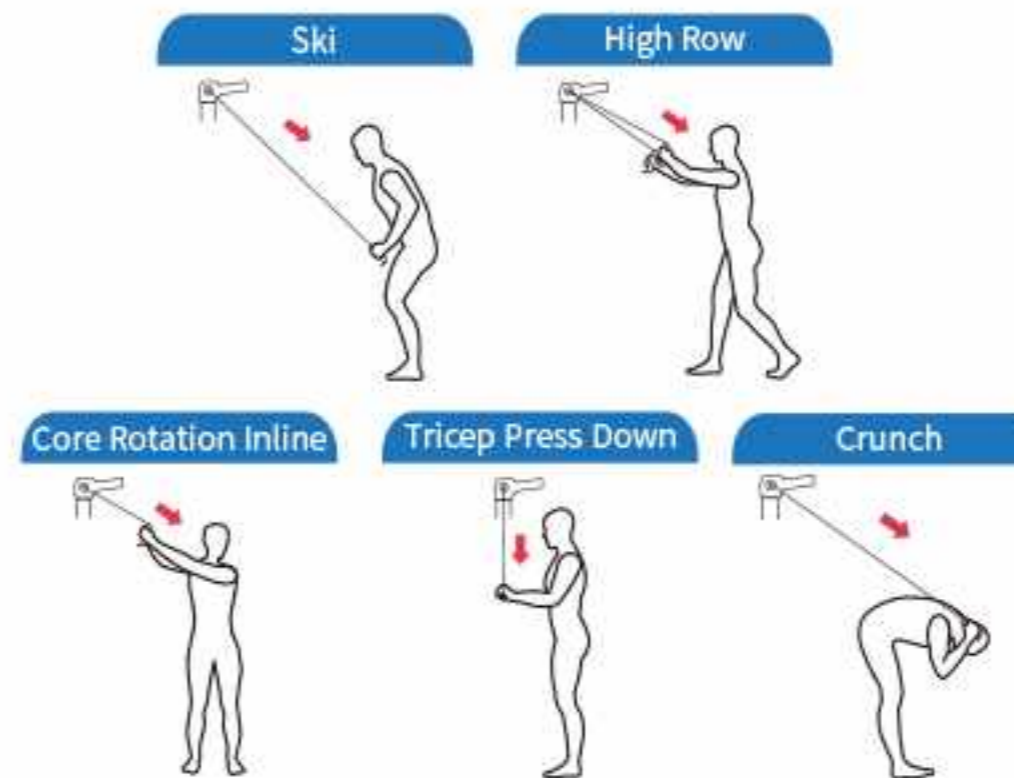

Skiing bar made of TPR materials allows for a comfortable grab feeling.

The transport wheels make it easy to place to a workout space.



A folding lock-up system ensures safety in daily using condition.



A folded Ski&Row saves 48% floor space comparing with rower form.



The SKI&ROW can be used in standing form, which provides upper body training and core training. Optional foot straps help users to train lower body and complete the workout shown below:



HSR007

● MARS (Magnetic & Air Resistance System)

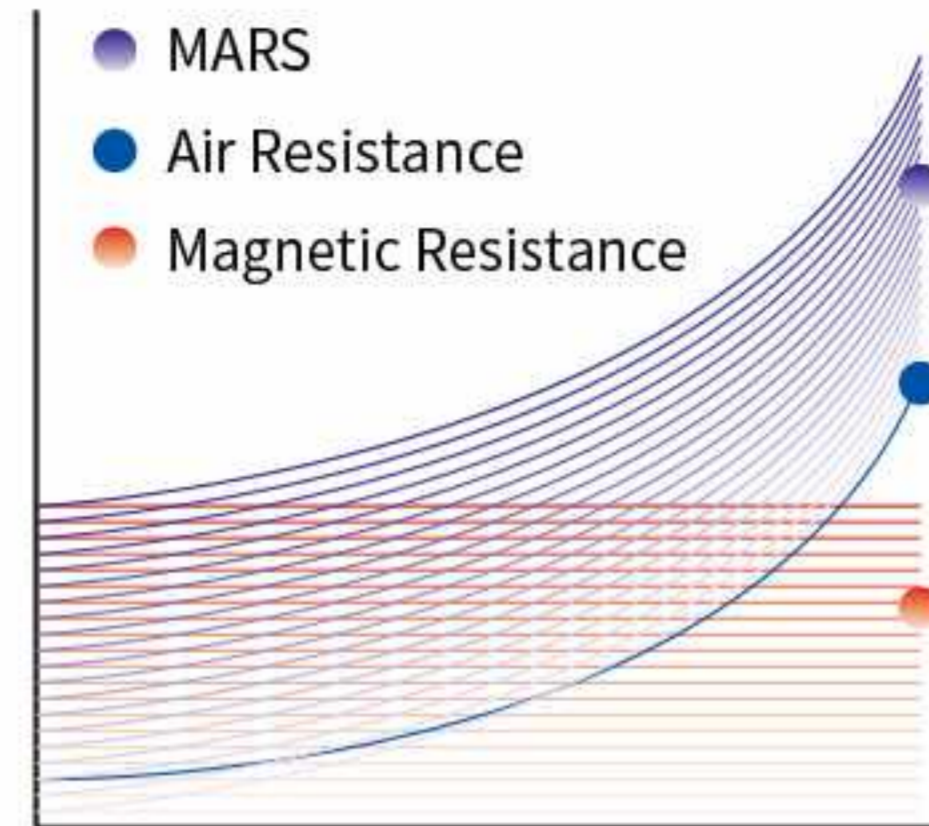
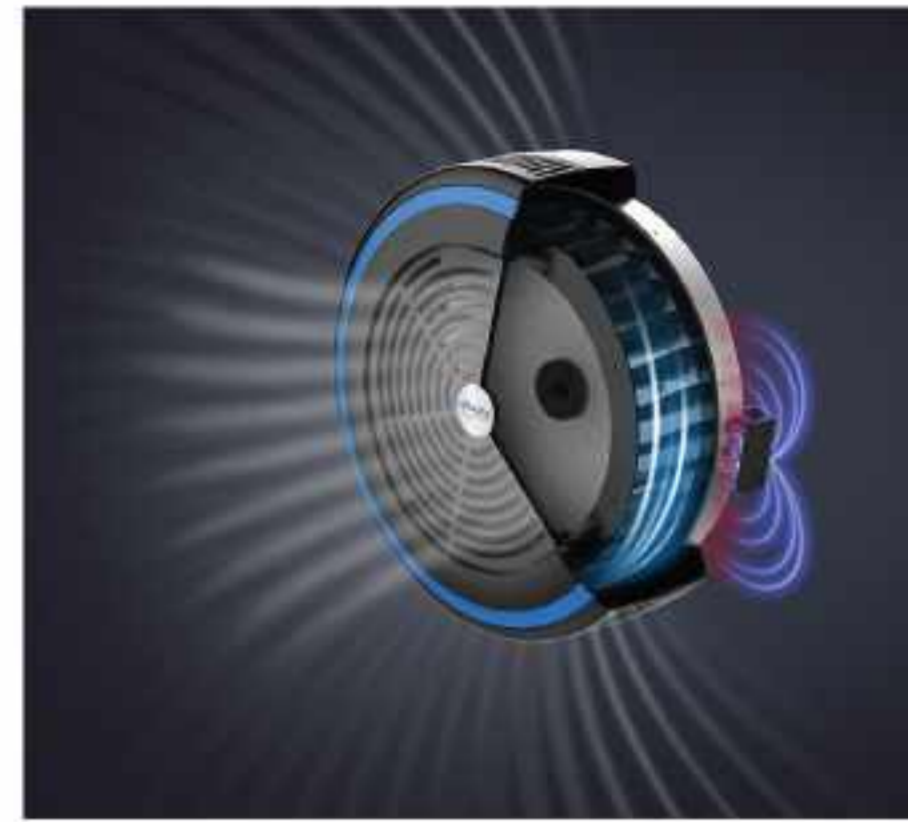

SKI & ROW Multiple Training Machine MARS (Magnetic & Air Resistance System) add a further resistance to the air resistance. The MARS system has 20 precise resistance levels. Through the console, users can easily adjust the resistance at all time.

Model	HSR007
Certification	CE
Maximum User Weight	150kg / 330lbs
Drive Model	Belt
Handlebar Design	Rowing Bar & Skiing Bar
Flywheel Weight	4.1kg
Special Features	Provided Rowing & Skiing Training
Resistance Design	MARS (Magnetic & Air Resistance System)
Resistance Power	300W
Resistance Levels	20
Console Display	5" LCD display with 8 readout windows
Console Readouts	Time, Stroke Rate, Pace, Distance, Watts, Calories, Heart Rate, Level
Programs	5(Time/Distance/Calorie Target, Interval Time/Distance)
HR Monitor	Telemetry
Power Requirements	4 C cell batteries
Product Dimension	Horizontal Form: 2620×810×1060(mm)/103.1"×31.9"×41.7" Vertical Form: 1360×810×2140(mm)/53.5"×31.9"×84.3
Seat Height	513mm/ 20.2"
Monorail	1663mm/ 65.5" (Aluminum)
Net Weight	66.5kg/146.3lbs
Packing Size	Box 1: 1805×565×170(mm)/71.1"×22.2"×6.7" Box 2: 1075×575×680(mm)/42.3"×22.6"×16.8"
40HC Container Count	98

● Space Saving Design

Thanks to the innovative design, the folded SKI & ROW Multiple Training Machine saves 48% space comparing with rowing form. Therefore, the SKI & ROW Multiple Training Machine as a commercial grade equipment is also suitable for the small fitness studio or residential.



HB005 ULTRA BIKE

The resistance is delivered by fan, which is driven by power and speed pedal along with two handles that move back and forth. Users are able to determine intensity level and resistance.



26 ABS blades molded into one piece which makes it stabilized and more quiet than traditional steel blades in using condition.



The workout data can be synchronized to your smart devices via Bluetooth or ANT+. Then you can track the data with 3rd party applications which manage your training more scientific. It helps users to make a more reasonable training plan.



Consider electroplated steel gets rust easily, the seat support and pedals of ULTRA BIKE is made of aluminum alloy, which is less prone to corrosion, helping to provide long service life.



Compared to ordinary ULTRA BIKE with its chain always sways and bumps and needs scheduled maintenance. ULTRA BIKE's V-Belt drive provides smooth and consistent ride without extra maintenance or high cost.

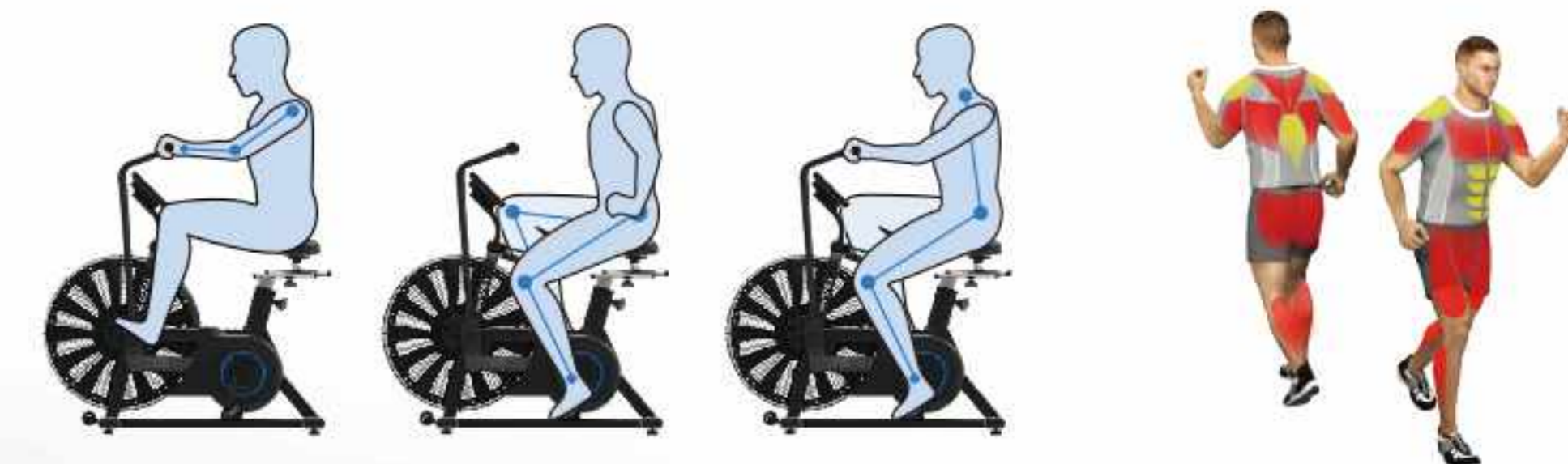

ULTRA BIKE enables users to do upper body training, lower body training and total body training. It helps to improve your body coordination and meets training demands of various people.

Model	HB005
Certification	CE
Maximum User Weight	150kg
Resistance	Air Resistance
Drive Model	Belt Drive
Pedals & handle bars	Synchronized Motion
Pedals	Double Faced Aluminum Alloy
Footholds	Aluminum
Crank	Oversize
Console Display	5"LCD Screen
Console Readouts	Time, Speed/Average Speed, Calories/Average Calories, Distance, RPM/Average RPM, Watt/Average Watt, Heart Rate/ Average Heart Rate
Programs	3 target programs (Time, Distance, Calories), 3 Heart Rate Programs (65%,75%,85%), 4 Interval Programs (3 time interval and 1 distance interval)
Heart Rate Monitor	Telemetry (Compatible with Polar heart rate belt)
Cup Holder	Yes
Fan Size	26 inches
Fan Blades	26 ABS Curved blades
Power Requirements	4 C Cell batteries
Product Dimension	1308×712×1349(mm)/51.5"×28.0"×53.1"
Net Weight	80kg/176lbs (TBD)
Gross Weight	90kg/198lbs (TBD)
Packing Size	1355×400×905(mm)/52.6"×15.7"×35.6"



INDOOR GROUP CYCLE

PS450 MAGNETIC INDOOR GROUP CYCLE

Resistance System	Magnetic
Emergency Stop	Push
Flywheel	Aluminum
Flywheel Weight	3.5kg
Pulley	Aluminum
Drivetrain	Belt
Drivetrain Ratio	1:10
Frame Material	Steel
Adjustment Type	Aluminum
Pedal	Dual-sided vp pedal
Shaft	φ25
Bearing	TPI
Handlebar	Multi-position, Soft PVC
Handlebar Adjustment	Vertical&Horizontal
Saddle	Ultra-padded sport saddle
Saddle Adjustments	Vertical&Horizontal
Water Bottle Holder	Double
Maximum User Weight	150kgs/330lbs
Gross Weight	55.8kg/123lbs
Net Weight	49.8kg/109.8lbs
Product Dimension	1272×609×1056(mm) 50.1"×23.9"×41.6"
Packing size	1310×315×1000(mm) 41.6"×12.4"×39.4"



Option: Console

Resistance Level	1-20
Metric/English	Metric/English
Console Readouts	Resistance Level, Time, Speed(AVG/MAX), Distance, Watt(AVG/MAX), RPM(AVG/MAX), Heart Rate(AVG/MAX), Calories
Console Display	4.5"LCD
Power Requirement	5# battery×4
Product Dimension	160×78×30.5 (mm)



Magnetic brake system provides more stable resistance, and more convenient adjustment.



V structure, 164mm Q-FACTOR allows ideal riding position



Seat and handles are adjustable horizontally and vertically. Aluminum post and newly designed knob allows convenient adjustment



Dual cup holders for intense training



Rear aluminum flywheel is waterproof. The plastic edge shroud ensures riding safety.



Dual-sided pedals allow riders to wear either cycling or athletic shoes.

Maintenance-free belt offers more quiet and smoothly riding experience.



Larger main frame, over-sized axis and pedal shaft ensure reliable quality.



Tension unit for stretch before and after riding





Handlebar
Vertically adjustable with nice hand feeling. Multiple handle positions can meeting various training needs.



Brake
Reliable Nylon nob brake. Coated steel cup holder is easy to access.



Seat
Precision casting seat part combined with chromium-plated steel adjusting tube make it easy to adjust position. Ergonomic seat pad provides comfortable training.



Resistance
Long-lasting pedals and classic fly wheel driving system brings nice training experience to users.



Frame
Double-oval tube and anti-rust steel frame makes extraordinary appearance.



CONSOLE



PS300



PS303



PS300 SPINNING BIKE

Resistance System	Wool brake
Emergency Stop	Push
Flywheel Weight	20kg/44lbs
Drivetrain	Chain
Pedal	Dual-sided vp pedal
Handlebar	Multi-position,Soft PVC
Handlebar Adjustment	Vertical & Horizontal
Max User Weight	150kg/330lbs
Gross Weight	66.3kg/145.9lbs
Net Weight	58.0kg/127.6lbs
Product Dimension	1200×530×1110(mm) 47.2"×20.9"×43.7"
Packing Size	1100×330×870(mm) 43.3"×13.0"×34.3"
40HC Container Count	222



STRENGTH

in impulse

EXOFORM

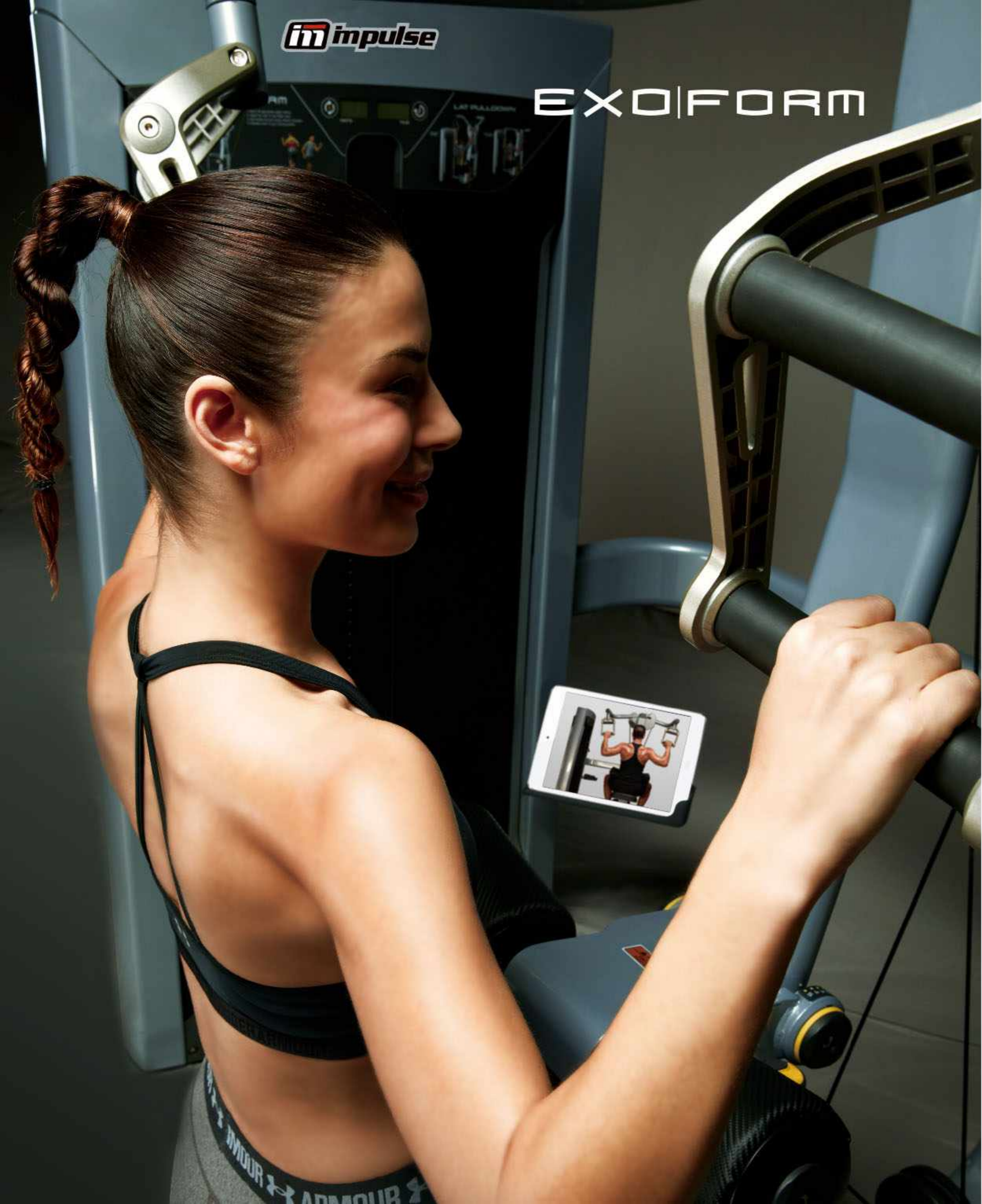

EXOFORM >>>

Uniformly low profile at 1492mm is designed by American team. Translucent shroud at thickness 3.2mm with smooth pattern is in injection molding, which designed elegantly and ensures ultra durability and non-deformation

Build-in console, which is well designed by American UI team, displays reps and time

The upright tubes are with special tube at size 72.8×141.7×3mm, and the functional part with race track tube at size 40×133×3mm. Tubes apply double powder-coated & painting process which ensure high-quality and ultra durability

The steel guide rod (diameter:19mm) is anti-corrosion coated and polished which ensures smoothly travel and rust-proof

Friendly designed iPad and bottle holders are separated to meet various requirement

The 5LBS incremental weight is to meet users requirement

Weight stack: 19mm full steel plate. Weight options-160/200/235/295Lbs

All the hardware parts exposed are nickel plated or stainless steel. The NBK bearing is applied

Meet EN957 safety regulation

Ergonomically designed handle bars, which is patented, are with TPU material and aluminium grip ring. The concise design offers comfort and safety

Ergonomically designed upholstery is with PU foam which offers comfort and safety protection

Belt and cable driving system are both applied. Self-lubricate American Loss cable with nylon-coated 12 complex fiber ensures service life 300,000 times. The belt is with steel wire embedded which ensures ultra durability and long lifetime

With spiral spring assistance system, the patented 3-linkage seat adjustment is concisely designed, cost-saving and offers easy installment

All dynamic components are shielded for safety purpose

Gas spring for resetting



* COLOR OPTIONAL.



FE9701 CHEST PRESS

Dimension (L×W×H)	1230x1570x1490(mm) 48.4x61.8x58.7 (in)
Net Weigh	169.7kg/373.3lbs



FE9702 LAT PULLDOWN

Dimension (L×W×H)	1305×1230×2010 (mm) 51.4x48.4x79.1 (in)
Net Weight	177.7kg/390.9lbs

FE9703 ARM CURL

Dimension (L×W×H)	1150x1567x1490(mm) 45.3x61.7x58.7 (in)
Net Weight	169.1kg/372lbs



FE9704 PECTORAL

Dimension (L×W×H)	1147x1551x1490 (mm) 45.2x61.1x58.7 (in)
Net Weight	131kg/288.2lbs (TBD)



FE9705 LEG EXTENSION

Dimension (L×W×H)	1300x1240x1490(mm) 51.2x48.8x58.7 (in)
Net Weight	169.6kg/373.1lbs



FE9708 ABDUCTOR/ADDUCTOR

Dimension (L×W×H)	1736x1500x1490 (mm) 68.3x59.1x58.7 (in)
Net Weight	165.8kg/364.8lbs



FE9706 SEATED LEG CURL

Dimension (L×W×H)	1242x1541x1490 (mm) 48.9x60.7x58.7 (in)
Net Weight	183.6kg/403.9lbs



FE9710 LEG PRESS

Dimension (L×W×H)	1785×1350×1490 (mm) 70.3x53.1x58.7 (in)
Net Weight	279kgs/613.8lbs



FE9712 SHOULDER PRESS

Dimension (L×W×H)	1765x1425x1490(mm) 69.5x56.1x58.7 (in)
Net Weight	168.7kg/371.1lbs

FE9715 PEC FLY/REAR DELT

Dimension (L×W×H)	1296x1758x1490(mm) 51x69.2x58.7 (in)
Net Weight	160.7kg/353.5lbs



FE9716 CALF RAISE

Dimension (L×W×H)	1265x1186x1721(mm) 49.8x46.7x67.8 (in)
Product Weight	167.8kg/369.2lbs



FE9714 ABDOMINAL

Dimension (L×W×H)	1385×1210×1490 (mm) 54.5x47.6x58.7 (in)
Net Weight	141.5kg/311.3lbs





FE9718 TORSO ROTATION

Dimension (L×W×H)	1291x1346x1490 (mm) 50.8x53.0x58.7 (in)
Net Weight	138.5kg/304.7lbs (TBD)



FE9720 WEIGHT ASSISTED CHIN/DIP COMBO

Dimension (L×W×H)	1750x1380x2200 (mm) 68.9x54.3x86.6 (in)
Net Weight	243.5kg/535.7lbs



FE9719 ROW

Dimension (L×W×H)	2000x1130x1490(mm) 78.7x44.5x58.7 (in)
Net Weight	174.8kg/384.6lbs



FE9721 PRONE LEG CURL

Dimension (L×W×H)	1705x1194x1490(mm) 67.1x47x58.7 (in)
Net Weight	154.2kg/339.2lbs



FE9723 TRICEP

Dimension (L×W×H)	1150x1580x1490(mm) 45.3x62.2x58.7 (in)
Net Weight	163.5kg/359.7lbs



FE9724 LATERAL RAISE

Dimension (L×W×H)	1261x1267x1490 (mm) 49.6x25.5x58.7 (in)
Net Weight	187.5kg/412.5lbs



FE9726 GLUTE

Dimension (L×W×H)	1304x1484x1490 (mm) 51.3x58.4x58.7 (in)
Net Weight	100kg/220lbs (TBD)



FE9732 BACK EXTENSION

Dimension (L×W×H)	1385x1225x1490(mm) 54.5x48.2x58.7 (in)
Net Weight	185.4kg/407.9lbs





in impulse

ARM CURL

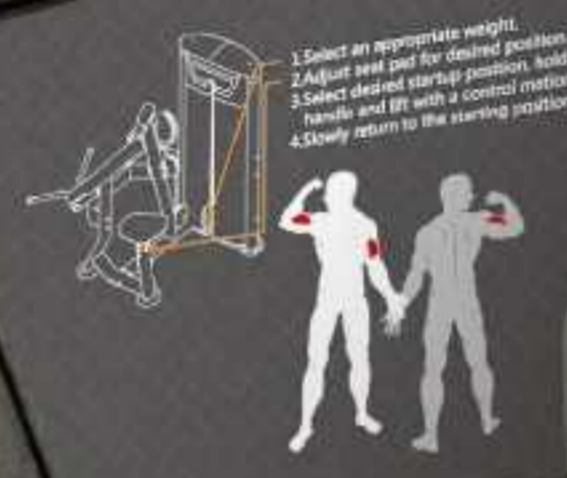

1. Select an appropriate weight.
2. Adjust seat and bar for desired position.
3. Select desired start-up position, hold handle and sit with a neutral posture.
4. Slowly return to the starting position.



IT95 Line >>>

Tube: 3mm tube in main frame and movement parts. U-frame uses PR95x81.1x3 tube and functional parts use RT50x100

Plastic part: Injection molding for better quality

Painting: Double coated surface treatment

Incremental weight (optional): 5lbs for smaller adjustment

Weight stack: 19mm full steel plate. Weight options - 160/200/235/295Lbs

Easy to enter and exit the machine and able to adjust when in sitting position

Conform with EN957. Passed 300,000 times fatigue test and 100kg stable test

Handle: Patented ergonomic design with TPU material

Standard metal part: Nickel plated or stainless steel for better appearance and quality

Diverging motion structure allows the arm training simultaneously and alternately

Pad: Double stitch and add protect cover on the back. Various colors to choose from

Pulley: Lathed pulley with less tolerance

Cable: USA imported cable which passed more than 250 thousand times test

Bearing: Reliable Taiwan brand



* COLOR OPTIONAL.

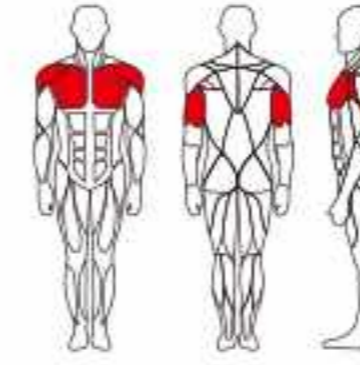

IT9501 CHEST PRESS

PRODUCT DIMENSION (LxWxH)	1475x1200x1506 (mm) 58.1x47.2x59.3 (in)
PRODUCT WEIGHT	127.4kg/280.3lbs

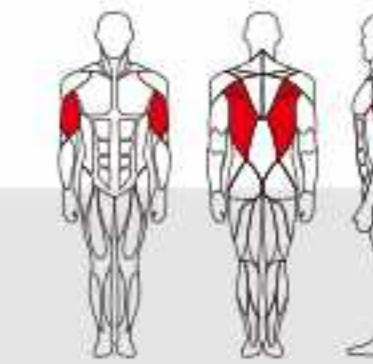

IT9502 LAT PULLDOWN

PRODUCT DIMENSION (LxWxH)	1384x1373x1889 (mm) 54.5x54.1x74.4 (in)
PRODUCT WEIGHT	147.7kg/324.9lbs

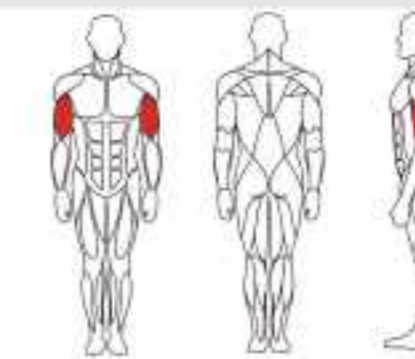

IT9503 ARM CURL

PRODUCT DIMENSION (LxWxH)	1295x1208x1506 (mm) 51.1x47.6x59.3 (in)
PRODUCT WEIGHT	115.5kg/254.1lbs



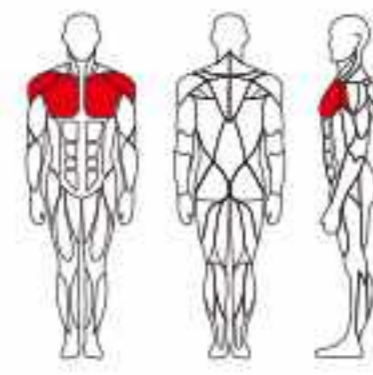

IT9504 PECTORAL

PRODUCT DIMENSION (LxWxH)	1450x1360x1510 (mm) 57.1x53.5x59.4 (in)
PRODUCT WEIGHT	132.5kg/291.5lbs

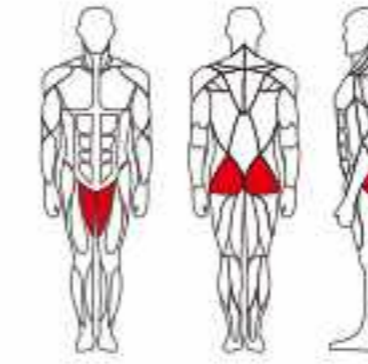

IT9508 ABDUCTOR/ADDUCTOR

PRODUCT DIMENSION (LxWxH)	1553x856x1506 (mm) 61.1x33.7x59.3 (in)
PRODUCT WEIGHT	149.6kg/329.1lbs

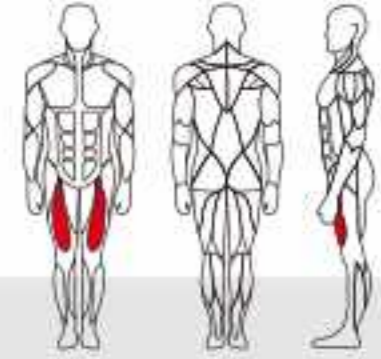

IT9505 LEG EXTENSION

PRODUCT DIMENSION (LxWxH)	1202x1189x1506 (mm) 47.3x46.8x59.3 (in)
PRODUCT WEIGHT	133.1kg/292.8lbs

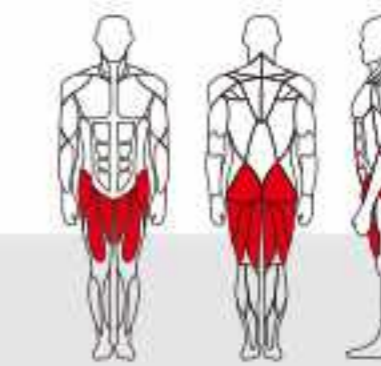

IT9509 TOTAL HIP

PRODUCT DIMENSION (LxWxH)	1292x972x1506 (mm) 50.9x38.3x59.3 (in)
PRODUCT WEIGHT	148.2Kg/326.7lbs

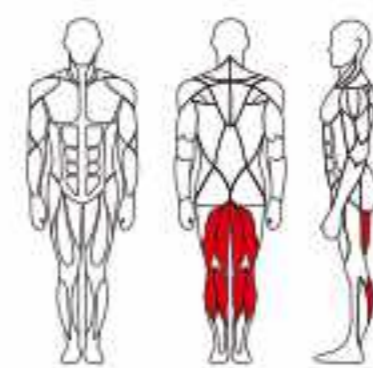

IT9506 SEATED LEG CURL

PRODUCT DIMENSION (LxWxH)	1536x1186x1506 (mm) 60.5x46.7x59.3 (in)
PRODUCT WEIGHT	149.6kg/329.1lbs

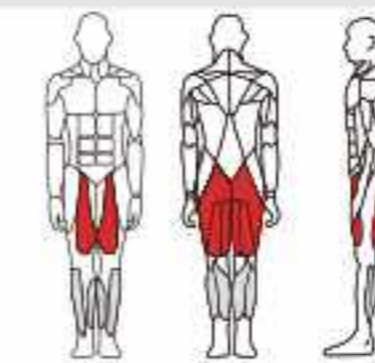

IT9510 LEG PRESS

PRODUCT DIMENSION (LxWxH)	1813x1109x1504 (mm) 71.4x43.7x59.2 (in)
PRODUCT WEIGHT	211.3kg/464.9lbs



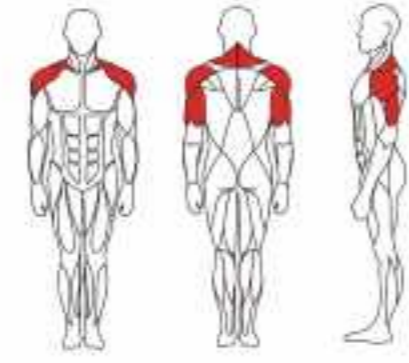

IT9512 SHOULDER PRESS

PRODUCT DIMENSION (LxWxH)	1560x1443x1510 (mm) 61.4x56.8x59.4 (in)
PRODUCT WEIGHT	137.4kg/302.3lbs

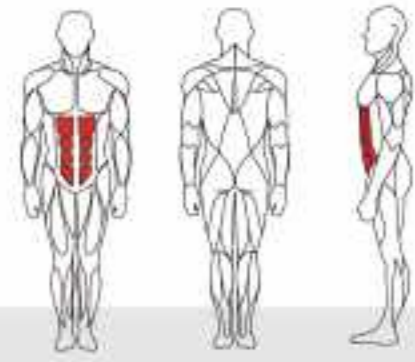

IT9514 ABDOMINAL

PRODUCT DIMENSION (LxWxH)	1345x1148x1581 (mm) 53.0x45.2x62.2 (in)
PRODUCT WEIGHT	112.6kg/247.7lbs

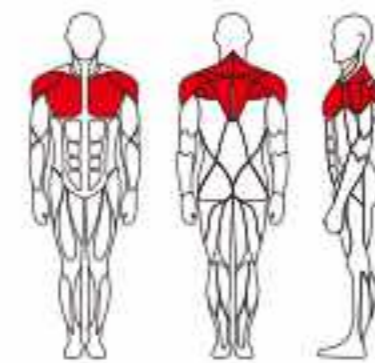

IT9515 PEC FLY/REAR DELT

PRODUCT DIMENSION (LxWxH)	1275x1288x2048 (mm) 50.2x50.7x80.6 (in)
PRODUCT WEIGHT	123.5kg/271.7lbs

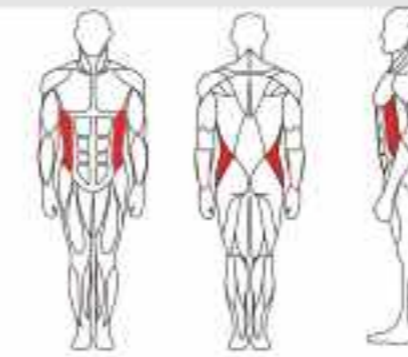

IT9518 TORSO ROTATION

PRODUCT DIMENSION (LxWxH)	1221x1202x1506(mm) 48.1x47.3x59.3 (in)
PRODUCT WEIGHT	150.8kg/331.8lbs

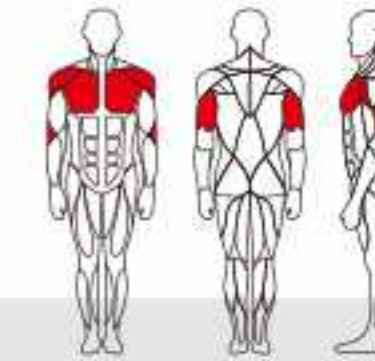

IT9517 SEATED DIP

PRODUCT DIMENSION (LxWxH)	1794x1267x1507(mm) 70.6x49.9x59.3 (in)
PRODUCT WEIGHT	142.5kg/313.5lbs

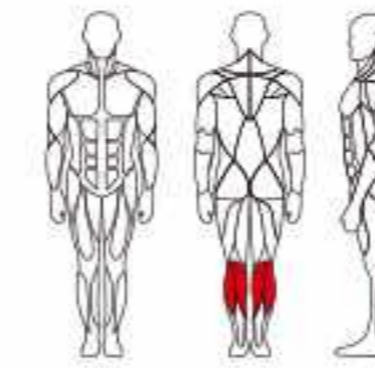

IT9516 CALF RAISE

PRODUCT DIMENSION (LxWxH)	1287x1156x1739 (mm) 50.7x45.5x68.5 (in)
PRODUCT WEIGHT	127.8kg/281.1lbs



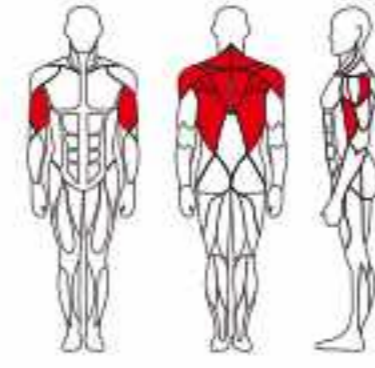

IT9519 VERTICAL ROW

PRODUCT DIMENSION (LxWxH)	1617×1264×1508(mm) 63.7x49.8x59.4 (in)
PRODUCT WEIGHT	126.5kg/278.3lbs

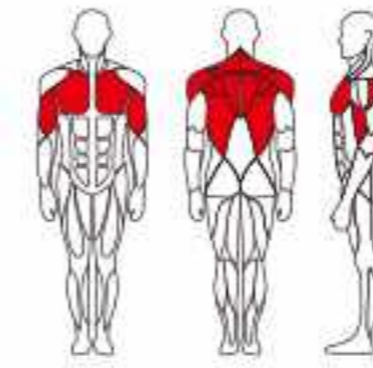
IT9522
LAT PULLDOWN/VERTICAL ROW

PRODUCT DIMENSION (LxWxH)	1897×1223×2228(mm) 74.7x48.1x87.7 (in)
PRODUCT WEIGHT	118.5kg/260.7lbs

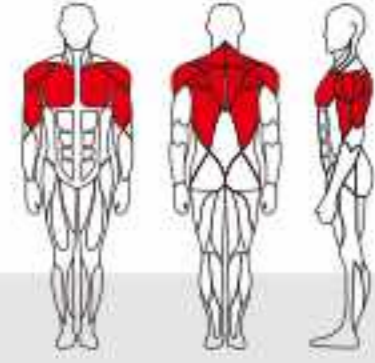
IT9520
WEIGHT ASSISTED CHIN/DIP COMBO

PRODUCT DIMENSION (LxWxH)	1570×1394×2286(mm) 61.8x54.9x90.0 (in)
PRODUCT WEIGHT	125.5kg/276.1lbs

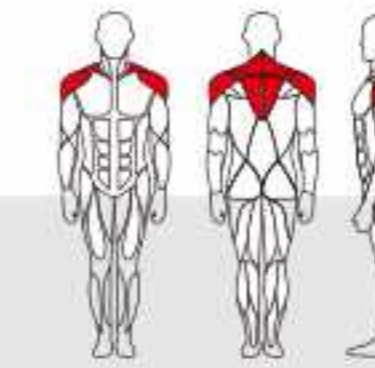

IT9524 LATERAL RAISE

PRODUCT DIMENSION (LxWxH)	1222x1213x1506 (mm) 48.1x47.8x59.3 (in)
PRODUCT WEIGHT	127.5kg/280.5lbs

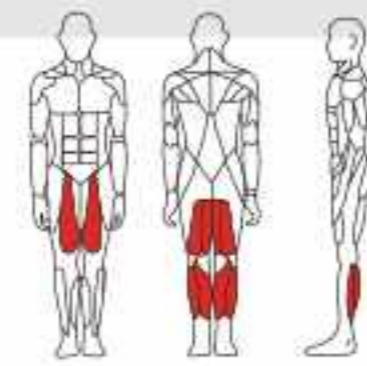

IT9521 PRONE LEG CURL

PRODUCT DIMENSION (LxWxH)	1443×1146×1508(mm) 56.8x45.1x59.4 (in)
PRODUCT WEIGHT	129.6kg/285.1lbs

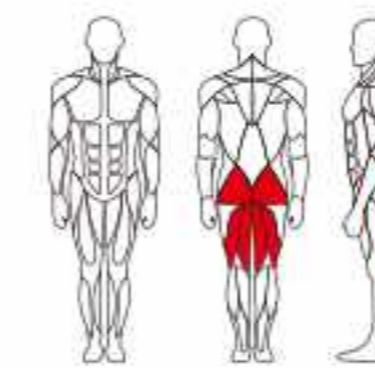

IT9526 GLUTE

PRODUCT DIMENSION (LxWxH)	1503x1245x1508 (mm) 59.2x49x59.4 (in)
PRODUCT WEIGHT	125.5kg/276.1lbs



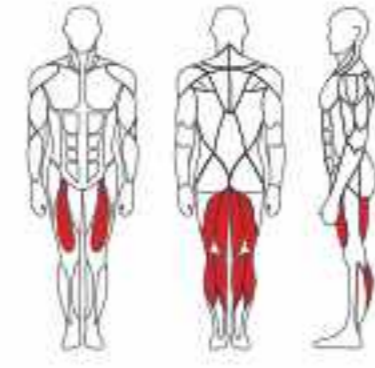

IT9528 LEG EXTENSION/LEG CURL

PRODUCT DIMENSION (LxWxH)	1375x1230x1507 (mm) 54.1x48.4x59.3 (in)
PRODUCT WEIGHT	167Kg/368.2lbs

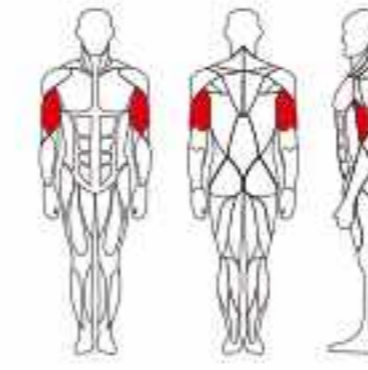

IT9533 BICEP CURL/TRICEP EXTENSION

PRODUCT DIMENSION (LxWxH)	1300x1225x1502(mm) 51.2x48.2x59.1(in)
PRODUCT WEIGHT	132.5kg/291.5lbs

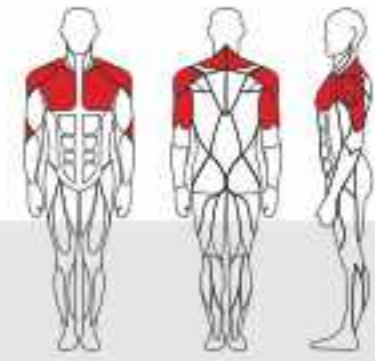

IT9529 MULTI PRESS

PRODUCT DIMENSION (LxWxH)	1827x1437x1669 (mm) 71.9x56.6x65.7 (in)
PRODUCT WEIGHT	166kg/365.9lbs

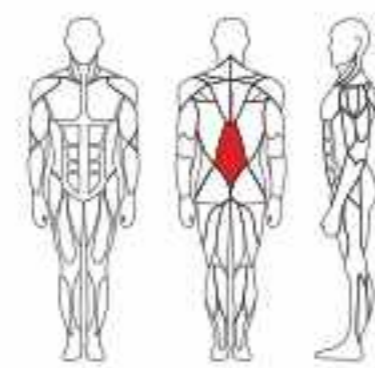

IT9532 BACK EXTENSION

PRODUCT DIMENSION (LxWxH)	1233x1188x1506 (mm) 48.5x56.8x59.3 (in)
PRODUCT WEIGHT	118.5kg/260.7lbs

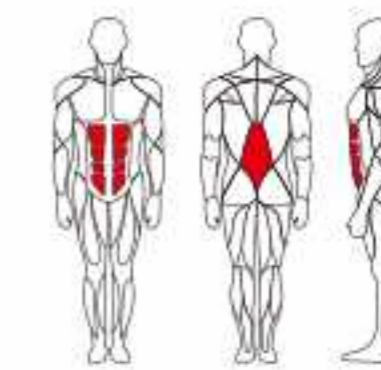

IT9534 ABDOMINAL/BACK EXTENSION

PRODUCT DIMENSION (LxWxH)	1196x1189x1506(mm) 53.4x50.8x61.7(in)
PRODUCT WEIGHT	139.2kg/306.2lbs

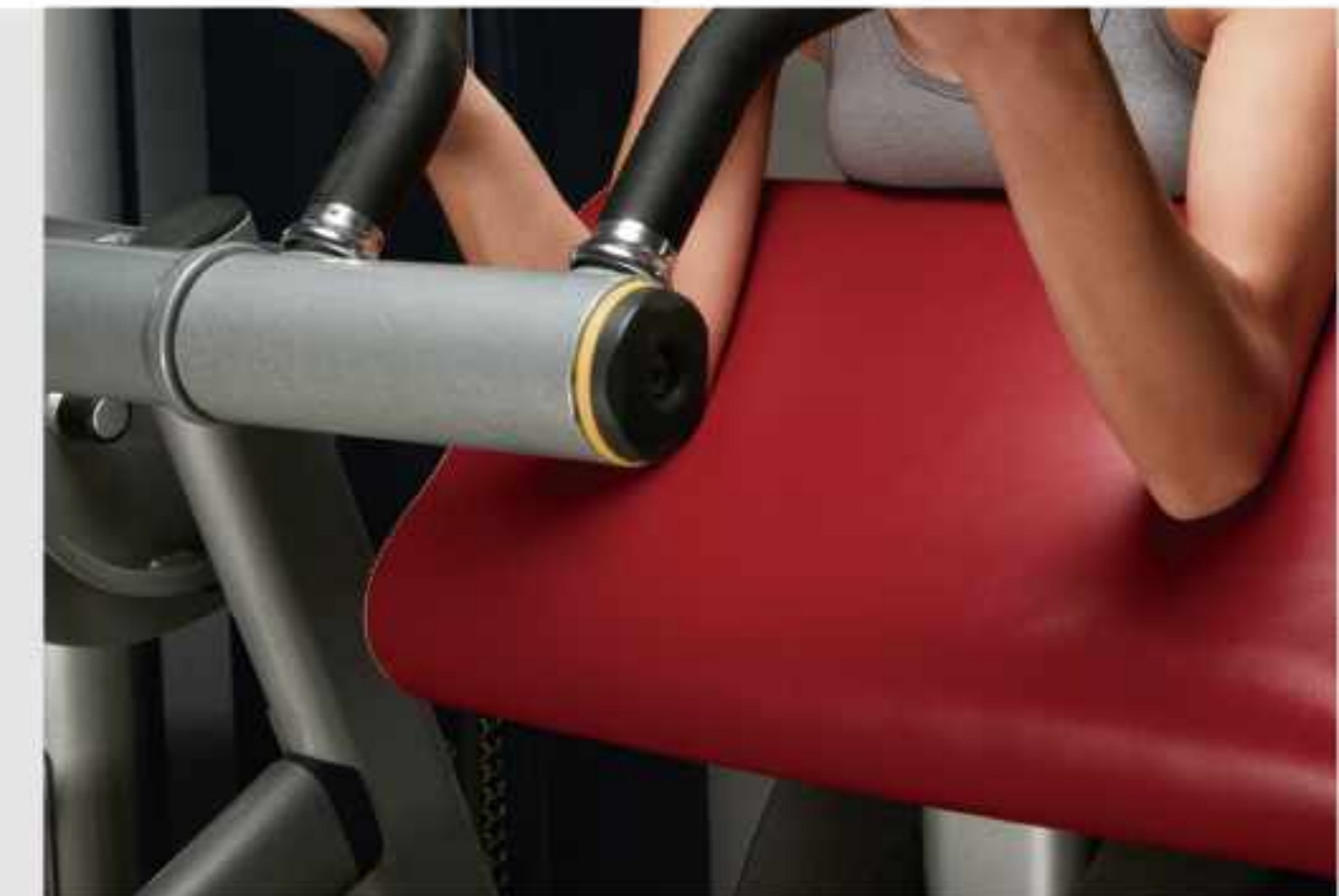



IT7001 SMITH

PRODUCT DIMENSION (L×W×H)	2241×1326×2370 (mm) 88.2×52.2×93.3 (in)
PRODUCT WEIGHT	178 kg / 392 lbs
40'	58 Sets
MAX. WEIGHT CAPACITY	200 kg / 440 lbs



IT7002 SEATED PREACHER CURL

PRODUCT DIMENSION (L×W×H)	919×803×882 (mm) 36.2×31.6×34.7 (in)
PRODUCT WEIGHT	41 kg / 90 lbs
40'	260 Sets



IT7005 SEATED CALF RAISE

PRODUCT DIMENSION (L×W×H)	1356×751×831 (mm) 53.4×29.6×32.7 (in)
PRODUCT WEIGHT	50 kg / 110 lbs
40'	297 Sets
MAX. WEIGHT CAPACITY	100 kg / 220 lbs



IT7006 LEG PRESS/HACK SQUAT

PRODUCT DIMENSION (L×W×H)	2253×975×1475 (mm) 88.7×38.4×58.1 (in)
PRODUCT WEIGHT	166.3 kg / 367 lbs
40'	66 Sets
MAX. WEIGHT CAPACITY	200 kg / 440 lbs



IT7003 AB BENCH

PRODUCT DIMENSION (L×W×H)	1745×936×997 (mm) 68.7×36.9×39.3 (in)
PRODUCT WEIGHT	57 kg / 126 lbs
40'	110 Sets



IT7004 STRETCH

PRODUCT DIMENSION (L×W×H)	1274×552×997 (mm) 50.2×21.7×39.3 (in)
PRODUCT WEIGHT	35 kg / 77 lbs
40'	280 Sets



IT7007 MULTI HYPEREXTENSION

PRODUCT DIMENSION (L×W×H)	1312×749×814 (mm) 51.7×29.5×32 (in)
PRODUCT WEIGHT	43.5 kg / 96 lbs
40'	231 Sets



IT7019 INCLINE ROW

PRODUCT DIMENSION (L×W×H)	1965×1009×1262 (mm) 77.4×39.7×49.7 (in)
PRODUCT WEIGHT	77.5 kg / 171 lbs
40'	140 Sets
MAX. WEIGHT CAPACITY	150 kg / 330 lbs



IT7020 45 LEG PRESS

PRODUCT DIMENSION (L×W×H)	2199×1016×1494 (mm) 86.6×40×58.8 (in)
PRODUCT WEIGHT	140.5 kg / 310 lbs
40'	71 Sets
MAX. WEIGHT CAPACITY	200 kg / 440 lbs



IT7014 FLAT BENCH PRESS

PRODUCT DIMENSION (L×W×H)	1657×1658×1373 (mm) 65.2×65.3×54.1 (in)
PRODUCT WEIGHT	82 kg / 181 lbs
40'	126 Sets



IT7014OPT SPOTTER STAND

PRODUCT DIMENSION (L×W×H)	661×442×262 (mm) 26.0×17.4×10.3 (in)
PRODUCT WEIGHT	25.1 kg/55.2 lbs
40'	680 Sets



IT7010 VERTICAL KNEE RAISE

PRODUCT DIMENSION (L×W×H)	1131×781×1515 (mm) 44.5×30.7×59.6 (in)
PRODUCT WEIGHT	53 kg / 117 lbs
40'	160 Sets



IT7010EOPT CHIN-UP AND DIP

DIMENSION (L×W×H)	2299×930×660 (mm) 90.5×36.6×26 (in)
PRODUCT WEIGHT	30.5kg/67.3lbs



IT7015 INCLINE BENCH PRESS

PRODUCT DIMENSION (L×W×H)	1632×1658×1373 (mm) 64.3×65.3×54.1 (in)
PRODUCT WEIGHT	106.5 kg / 235 lbs
40'	112 Sets



IT7016 DECLINE BENCH PRESS

PRODUCT DIMENSION (L×W×H)	2103×1658×1370 (mm) 82.8×65.3×53.9 (in)
PRODUCT WEIGHT	87 kg / 192 lbs
40'	126 Sets



IT7013 MULTI AB BENCH

PRODUCT DIMENSION (L×W×H)	1738×725×899 (mm) 68.4×28.5×35.4 (in)
PRODUCT WEIGHT	42.5 kg / 94 lbs
40'	140 Sets



IT7009 FLAT BENCH

PRODUCT DIMENSION (L×W×H)	1200×748.6×426(mm) 47.2×29.5×16.8 (in)
PRODUCT WEIGHT	27.5 kg / 61 lbs
40'	220 Sets



IT7011 MULTI-ADJUSTABLE BENCH

PRODUCT DIMENSION (L×W×H)	1212×750×465 (mm) 47.7×29.5×18.3 (in)
PRODUCT WEIGHT	40 kg / 88 lbs
40'	207 Sets



IT7022 UTILITY BENCH

PRODUCT DIMENSION (L×W×H)	1165×603×818 (mm) 45.9×23.7×32.2 (in)
PRODUCT WEIGHT	21.3 kg / 47 lbs
40'	308 Sets



IT7030 ABDOMINAL BENCH

DIMENSION (L×W×H)	985×726×625 (mm) 38.8×28.6×24.6 (in)
PRODUCT WEIGHT	35kg/77.2lbs



IT7012 DUMBBELL RACK

PRODUCT DIMENSION (L×W×H)	1508×814×938(mm) 59.4×32.0×36.9(in)
PRODUCT WEIGHT	71kg/156lbs
40'	140Sets



IT7018 DUMBBELL RACK

PRODUCT DIMENSION (L×W×H)	1580×814×982 (mm) 62.2×32×38.7 (in)
40'	140 Sets



IT7031 SHOULDER BENCH PRESS

DIMENSION (L×W×H)	1349×1126×1651(mm) 53.1×44.3×65(in)
PRODUCT WEIGHT	86.5 kg/190.9 lbs
MAX. WEIGHT CAPACITY	300 kg/660 lbs



IT7017 WEIGHT PLATE TREE

PRODUCT DIMENSION (L×W×H)	950×610×1220 (mm) 37.4×24×48 (in)
PRODUCT WEIGHT	26 kg / 57 lbs
40'	264 Sets

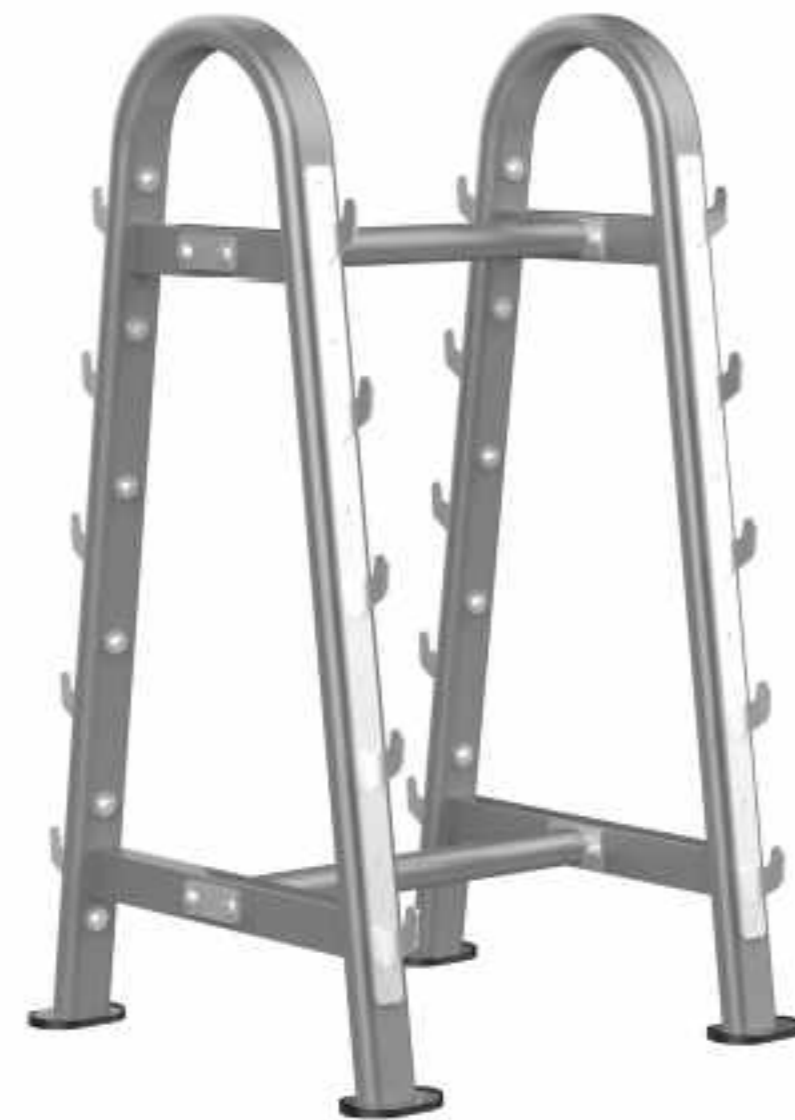

IT7027 BARBELL RACK

PRODUCT DIMENSION (L×W×H)	919×907×1612 (mm) 36.2×35.7×63.5 (in)
PRODUCT WEIGHT	68 kg / 150 lbs
40'	112 Sets



IT7032 OLYMPIC BAR RACK

DIMENSION (L×W×H)	960×710×1086(mm) 37.8×28×42.8(in)
PRODUCT WEIGHT	47 kg/103.7 lbs
MAX. WEIGHT CAPACITY	300 kg/660 lbs

IT7033 MAX RACK

DIMENSION (L×W×H)	2000×1410×2185(mm) 78.7×55.5×86(in)
PRODUCT WEIGHT	199.4 kg/440 lbs
MAX. WEIGHT CAPACITY	200 kg/440 lbs





PL Line >>>

Easy to use, neat appearance, the PL line is a high quality dual/multi functional machines Light commercial/commercial series. This PL line is Impulse dual/multi functional line. The user-friendly design makes working out more simple, efficient, comfortable and satisfying.

Instructive - simple, step-by-step instructions and training tips help users get the most out of their exercise.

Aircraft spec 5mm American LOOS cable with a 2,000 lb breaking strength. End fittings tested to 250,000 cycles using full weight stack.

Easy-to-use, minimal adjustments and pre-stretch features allow for optimal exercise positions.

Glass fiber reinforced nylon pulleys with deep V-groove provides secure cable seating and fluid bearing rotation.

Compact - space efficient design requires minimal floor space.

Shroud is applied to protect the equipment or the possible injury during operation.

Tubing: 2.5 mm to 2.75mm. square tube differ into any types, from 30x60mm to 50x100mm, electro-welded to maximum integrity.

Pad total thickness is 70mm.



Color: metallic silver gray (Other colors are optional based on customer requirements)



PL9002
LAT PULLDOWN/SEATED ROW

PRODUCT DIMENSION (L×W×H)	1764×1019×2182 (mm) 69.4×40.1×85.9 (in)
PRODUCT WEIGHT	90.5 kg / 200 lbs
40'	136 Sets



PL9010
LEG PRESS/CALF RAISE

PRODUCT DIMENSION (L×W×H)	1938×1148×1520 (mm) 76.3×45.2×59.8 (in)
PRODUCT WEIGHT	111 kg / 245 lbs
40'	88 Sets



PL9021 MULTI PRESS

PRODUCT DIMENSION (L×W×H)	1924×1325×1518 (mm) 75.7×52.2×59.8 (in)
PRODUCT WEIGHT	111.5 kg / 246 lbs
40'	120 Sets



PL9022
REAR DELTOID/PECTORAL FLY

PRODUCT DIMENSION (L×W×H)	1362×1219×2061 (mm) 53.6×48.0×81.1 (in)
PRODUCT WEIGHT	107 kg / 236 lbs
40'	124 Sets



PL9016
OUTER/INNER THIGH

PRODUCT DIMENSION (L×W×H)	1609×722×1515 (mm) 63.3×28.4×59.6 (in)
PRODUCT WEIGHT	99 kg / 218 lbs
40'	130 Sets



PL9019
LEG EXTENSION/LEG CURL

PRODUCT DIMENSION (L×W×H)	1465×1245×1520 (mm) 57.7×49×59.8 (in)
PRODUCT WEIGHT	115.5 kg / 255 lbs
40'	75 Sets



PL9023 BICEPS/TRICEPS

PRODUCT DIMENSION (L×W×H)	1207×1164×1513 (mm) 47.5×45.8×59.6 (in)
PRODUCT WEIGHT	106 kg / 234 lbs
40'	115 Sets



PL9024 AB/LOW BACK

PRODUCT DIMENSION (L×W×H)	1044×1094×1520 (mm) 41.1×43.1×59.8 (in)
PRODUCT WEIGHT	99.5 kg / 219 lbs
40'	135 Sets

IF93 >>>

These simple, clean-lines, selectorized series specially designed for entry level small clubs and institutional applications. It offers a complete functional package, is inexpensive to own and is easy to maintain. It matches up beautifully with the benches and racks of the IF line.

The clear and precise instructions and training tips are great for individuals who is new to strength training and help users to build targeted muscle .

Specially designed cup holder is perfectly integrated with cage, making it simple and generous.

The translucent shroud with ABS materials (optional front shroud) is durable and wear resisting. The main plastic parts are made using injection molding that help to provide steady quality.

The upright tubing thickness of 2.5mm and the functional parts with rectangular tube at size of 50×100×2.5mm, which make IF93 stronger and more powerful.

The whole series are adopted with the equivalent cage height of 1530mm, which help to create a bright training environment of fitness club.

All pulleys are adopted with high quality bearings which ensure smooth movement.

Ergonomic seat cushion, chest and back pad are made of polymer materials. The specially designed pads have different angles, which meet various training requirements.

Ergonomically designed handle bars are made of TPV materials, which make your garb more comfortable and safety. It combines with aluminum end cap reflecting high-end taste.

The main frame is coated with materials that environmental friendly, which helps to improve products quality and provide with good scratching and corrosion resistance.

Designed with stainless steel seat adjustment that provides a longer service life, made it easy to adjust and look beautiful.



* THE FRONT SHROUD IS OPTIONAL.
(Weight stacks varies by the shrouds)
160 lbs/200 lbs/235 lbs/295 lbs
Weight Stack Available





IF9301 CHEST PRESS

PRODUCT DIMENSION (L×W×H)	1040×1360×1530 (mm) 40.5×53.5×60.2 (in)
PRODUCT WEIGHT	97.1kg
STANDARD WEIGHT STACK	91kg
OPTIONAL WEIGHT STACK	72kg/106kg/134kg



IF9302 LAT PULLDOWN

PRODUCT DIMENSION (L×W×H)	1585×1318×1891 (mm) 42.4×51.9×74.4 (in)
PRODUCT WEIGHT	100kg
STANDARD WEIGHT STACK	91kg
OPTIONAL WEIGHT STACK	72kg/106kg /134kg



IF9305 LEG EXTENSION

PRODUCT DIMENSION (L×W×H)	1146×1050×1530 (mm) 45.1×41.3×60.2 (in)
PRODUCT WEIGHT	101.5kg
STANDARD WEIGHT STACK	91kg
OPTIONAL WEIGHT STACK	72kg/106kg /134kg



IF9306 SEATED LEG CURL

PRODUCT DIMENSION (L×W×H)	1148×1034×1530 (mm) 45.2×40.7×60.2 (in)
PRODUCT WEIGHT	95kg
STANDARD WEIGHT STACK	91kg
OPTIONAL WEIGHT STACK	91kg/106kg/134kg



IF9303 ARM CURL

PRODUCT DIMENSION (L×W×H)	1216×1028×1530 (mm) 47.9×40.5×60.2 (in)
PRODUCT WEIGHT	90kg
STANDARD WEIGHT STACK	72kg
OPTIONAL WEIGHT STACK	91kg/106kg /134kg



IF9304 PECTORAL

PRODUCT DIMENSION (L×W×H)	1736×806×1530 (mm) 68.3×31.7×60.2 (in)
PRODUCT WEIGHT	95kg(TBD)
STANDARD WEIGHT STACK	91kg
OPTIONAL WEIGHT STACK	72kg/106kg /134kg



IF9310 LEG PRESS

PRODUCT DIMENSION (L×W×H)	1790×1168×1530 (mm) 70.5×46.0×60.2(in)
PRODUCT WEIGHT	120.5kg
STANDARD WEIGHT STACK	134kg
OPTIONAL WEIGHT STACK	91kg/72kg/106kg



IF9312 SHOULDER PRESS

PRODUCT DIMENSION (L×W×H)	1149×1456×1530 (mm) 45.2×57.3×60.2 (in)
PRODUCT WEIGHT	102.6kg
STANDARD WEIGHT STACK	91kg
OPTIONAL WEIGHT STACK	72kg/106kg/134kg

* The right of specific weight to actual supply prevail.



IF9314 ABDOMINAL

PRODUCT DIMENSION (L×W×H)	1304×1484×1490 (mm) 51.3×58.4×58.7 (in)
PRODUCT WEIGHT	89.5kg
STANDARD WEIGHT STACK	91kg
OPTIONAL WEIGHT STACK	72kg/106kg/134kg



IF9315 PECTORAL

PRODUCT DIMENSION (L×W×H)	1493×1421×1863 (mm) 58.8×55.9×73.3 (in)
PRODUCT WEIGHT	90kg(TBD)
STANDARD WEIGHT STACK	91kg
OPTIONAL WEIGHT STACK	72kg/106kg/134kg



IF9318 TORSO ROTATION

PRODUCT DIMENSION (L×W×H)	1240×1105×1530 (mm) 48.8×43.5×60.2(in)
PRODUCT WEIGHT	96kg
STANDARD WEIGHT STACK	91kg
OPTIONAL WEIGHT STACK	72kg/106kg/134kg



IF9319 VERTICAL ROW

PRODUCT DIMENSION (L×W×H)	1818×870×1530 (mm) 71.6×34.3×60.2(in)
PRODUCT WEIGHT	91.5kg
STANDARD WEIGHT STACK	91kg
OPTIONAL WEIGHT STACK	72kg/106kg/134kg



IF9316 CALF RAISE

PRODUCT DIMENSION (L×W×H)	1150×1105×1775 (mm) 45.3×43.5×69.9(in)
PRODUCT WEIGHT	106kg
STANDARD WEIGHT STACK	134kg
OPTIONAL WEIGHT STACK	91kg/72kg/106kg



IF9317 SEATED DIP

PRODUCT DIMENSION (L×W×H)	1227×1212×1530 (mm) 48.3×47.7×60.2(in)
PRODUCT WEIGHT	97.5kg
STANDARD WEIGHT STACK	91kg
OPTIONAL WEIGHT STACK	72kg/106kg/134kg

IF9320
WEIGHT ASSISTED CHIN/DIP COMBO

PRODUCT DIMENSION (L×W×H)	1309×1256×2498 (mm) 51.5×49.4×98.3(in)
PRODUCT WEIGHT	107kg
STANDARD WEIGHT STACK	91kg
OPTIONAL WEIGHT STACK	72kg/106kg/134kg



IF9321 PRONE LEG CURL

PRODUCT DIMENSION (L×W×H)	1510×1150×1530 (mm) 59.4×45.3×60.2(in)
PRODUCT WEIGHT	101.5kg
STANDARD WEIGHT STACK	91kg
OPTIONAL WEIGHT STACK	72kg/106kg/134kg



IF9322 LAT PULLDOWN

PRODUCT DIMENSION (L×W×H)	1886×1223×2227 (mm) 74.2×48.1×87.7(in)
PRODUCT WEIGHT	90kg(TBD)
STANDARD WEIGHT STACK	72kg
OPTIONAL WEIGHT STACK	91kg/106kg/134kg



IF9323 ARM EXTENSION

PRODUCT DIMENSION (L×W×H)	1079×1028×1530 (mm) 42.1×40.5×60.2 (in)
PRODUCT WEIGHT	91kg
STANDARD WEIGHT STACK	72kg
OPTIONAL WEIGHT STACK	91kg/106kg/134kg



IF9332 BACK EXTENSION

PRODUCT DIMENSION (L×W×H)	1120×1034×1530 (mm) 44.0×40.7×60.2 (in)
PRODUCT WEIGHT	98kg
STANDARD WEIGHT STACK	91kg
OPTIONAL WEIGHT STACK	72kg/106kg/134kg



IF9335 ABDUCTOR

PRODUCT DIMENSION (L×W×H)	1583×946×1530 (mm) 62.3×37.2×60.2(in)
PRODUCT WEIGHT	95kg
STANDARD WEIGHT STACK	72kg
OPTIONAL WEIGHT STACK	91kg/106kg/134kg



IF9324 LATERAL RAISE

PRODUCT DIMENSION (L×W×H)	1179×750×1530 (mm) 46.4×29.5×60.2(in)
PRODUCT WEIGHT	85kg
STANDARD WEIGHT STACK	91kg
OPTIONAL WEIGHT STACK	72kg/106kg/134kg



IF9326 KICK BACK

PRODUCT DIMENSION (L×W×H)	1068×1034×1530 (mm) 42.0×40.7×60.2 (in)
PRODUCT WEIGHT	90kg(TBD)
STANDARD WEIGHT STACK	91kg
OPTIONAL WEIGHT STACK	72kg/106kg/134kg



IF9336 ADDUCTOR

PRODUCT DIMENSION (L×W×H)	1583×1036×1530 (mm) 62.3×40.8×60.2(in)
PRODUCT WEIGHT	95kg
STANDARD WEIGHT STACK	72kg
OPTIONAL WEIGHT STACK	91kg/106kg/134kg



IFHC HALF CAGE

PRODUCT DIMENSION (L×W×H)	1690×1725×2090 (mm) 66.5×67.9×82.3 (in)
PRODUCT WEIGHT	100 kg / 221 lbs
40'	150 Sets



IFHCL HALF CAGE LAT ATTACHMENT

PRODUCT DIMENSION (L×W×H)	1800×400×2100 (mm) 70.9×15.7×82.7 (in)
PRODUCT WEIGHT	41 kg / 90 lbs
40'	234 Sets



IFHCP HALF CAGE PEC FLY ATTACHMENT

PRODUCT DIMENSION (L×W×H)	953×356×1538 (mm) 37.5×14×60.6 (in)
PRODUCT WEIGHT	24.3 kg / 54 lbs
40'	508 Sets



IFHCS HALF CAGE SMITH ATTACHMENT

PRODUCT DIMENSION (L×W×H)	1946×300×1727 (mm) 76.6×11.8×68 (in)
PRODUCT WEIGHT	33 kg / 73 lbs
40'	425 Sets
MAX. WEIGHT CAPACITY	200 kg / 440 lbs

IFLATM LAT MACHINE

PRODUCT DIMENSION (L×W×H)	1452×1224×2129 (mm) 57.2×48.2×83.8 (in)
PRODUCT WEIGHT	55.5 kg / 122 lbs
40'	302 Sets



IFPC POWER CAGE

PRODUCT DIMENSION (L×W×H)	1231×1231×2110 (mm) 48.5×48.5×83.1 (in)
PRODUCT WEIGHT	114 kg / 251 lbs
40'	90 Sets

IFPCL POWER CAGE LAT ATTACHMENT

PRODUCT DIMENSION (L×W×H)	2061×1213×958 (mm) 81.1×47.8×37.7 (in)
PRODUCT WEIGHT	31.8 kg / 70 lbs
40'	420 Sets





**IF45 45-DEGREE
HYPEREXTENSION**

PRODUCT DIMENSION (L×W×H)	1212×743×772 (mm) 47.7×29.3×30.4 (in)
PRODUCT WEIGHT	23.5 kg / 52 lbs
40'	340 Sets



**IFAH ADJUSTABLE
HYPEREXTENSION BENCH**

PRODUCT DIMENSION (L×W×H)	1260×743×917 (mm) 49.6×29.3×36.1 (in)
PRODUCT WEIGHT	36 kg / 79 lbs
40'	360 Sets



**IFRC
ROMAN CHAIR**

PRODUCT DIMENSION (L×W×H)	1361×743×1091 (mm) 53.6×29.3×43 (in)
PRODUCT WEIGHT	30.5 kg / 67 lbs
40'	504 Sets



**IFFB
FLAT BENCH**

PRODUCT DIMENSION (L×W×H)	1305×525×493 (mm) 51.4×20.7×19.4 (in)
PRODUCT WEIGHT	19.5 kg / 43 lbs
40'	532 Sets



**IFUB
UTILITY BENCH**

PRODUCT DIMENSION (L×W×H)	862×596×874 (mm) 33.9×23.5×34.4 (in)
PRODUCT WEIGHT	12.7 kg / 28 lbs
40'	375 Sets



**IFFI
FLAT/INCLINE BENCH**

PRODUCT DIMENSION (L×W×H)	1603×654×498 (mm) 63.1×25.7×19.6 (in)
PRODUCT WEIGHT	30 kg / 66 lbs
40'	396 Sets



**IFSPC SEATED
PREACHER CURL**

PRODUCT DIMENSION (L×W×H)	1021×712×824 (mm) 40.2×28×32.4 (in)
PRODUCT WEIGHT	24.7 kg / 54 lbs
40'	420 Sets



**IFAAB ADJUSTABLE
ABDOMINAL BENCH**

PRODUCT DIMENSION (L×W×H)	1683×568×1148 (mm) 66.3×22.4×45.2 (in)
PRODUCT WEIGHT	24 kg / 53 lbs
40'	450 Sets



**IFAC
ABDOMINAL CRUNCH**

PRODUCT DIMENSION (L×W×H)	1103×476×578 (mm) 43.4×18.7×22.8 (in)
PRODUCT WEIGHT	17 kg / 37 lbs
40'	697 Sets



**IFOB
OLYMPIC BENCH PRESS**

PRODUCT DIMENSION (L×W×H)	1438×1264×1468 (mm) 56.6×49.8×57.8 (in)
PRODUCT WEIGHT	62.5 kg / 138 lbs
40'	252 Sets



**IFARMA
ARM CURL ATTACHMENT**

PRODUCT DIMENSION (L×W×H)	584×434×761 (mm) 23×17.1×30 (in)
PRODUCT WEIGHT	6.6 kg / 15 lbs
40'	840 Sets



**IFLEGA
LEG EXTENSION/CURL ATTACHMENT**

PRODUCT DIMENSION (L×W×H)	485×426×470 (mm) 19.1×16.8×18.5 (in)
PRODUCT WEIGHT	7.3 kg / 16 lbs
40'	1728 Sets



IFSTF
STRETCH

PRODUCT DIMENSION (L×W×H)	1866×1730×2150 (mm) 73.5×68.1×84.6 (in)
PRODUCT WEIGHT	90 kg / 198 lbs
40'	112 Sets



IFPT
POWER TOWER

PRODUCT DIMENSION (L×W×H)	1320×610×2105 (mm) 52×24×82.9 (in)
PRODUCT WEIGHT	76.5 kg / 169 lbs
40'	245 Sets



IFSS
SQUAT STAND

PRODUCT DIMENSION (L×W×H)	1226×1575×1735 (mm) 48.3×62×68.3 (in)
PRODUCT WEIGHT	56.5 kg / 125 lbs
40'	320 Sets



IFOFB
FLAT BENCH PRESS

PRODUCT DIMENSION (L×W×H)	1525×1310×1265 (mm) 60×51.6×49.8 (in)
PRODUCT WEIGHT	60.5 kg / 133 lbs
40'	154 Sets



IFOIB
INCLINE BENCH PRESS

PRODUCT DIMENSION (L×W×H)	1560×1310×1192 (mm) 61.4×51.6×46.9 (in)
PRODUCT WEIGHT	68.5 kg / 151 lbs
40'	147 Sets



IFLPHS
LEG PRESS/HACK SQUAT MACHINE

PRODUCT DIMENSION (L×W×H)	2285×820×1295 (mm) 90×32.3×51 (in)
PRODUCT WEIGHT	162.5 kg / 358 lbs
40'	108 Sets
MAX. WEIGHT CAPACITY	200 kg / 440 lbs



IFFID
MULTI-PURPOSE BENCH

PRODUCT DIMENSION (L×W×H)	1581×654×515 (mm) 62.2×25.7×20.3 (in)
PRODUCT WEIGHT	33 kg / 73 lbs
40'	417 Sets



IFODB
DECLINE BENCH PRESS

PRODUCT DIMENSION (L×W×H)	1900×1310×1156 (mm) 74.8×51.6×45.5 (in)
PRODUCT WEIGHT	70 kg / 154 lbs
40'	154 Sets





IFABM
AB/BACK MACHINE

PRODUCT DIMENSION (L×W×H)	1520×1005×1060 (mm) 59.8×39.6×41.7 (in)
PRODUCT WEIGHT	38.5 kg / 85 lbs
40'	119 Sets



IFCR
CALF RAISE

PRODUCT DIMENSION (L×W×H)	1100×560×850 (mm) 43.3×22×33.5 (in)
PRODUCT WEIGHT	35.5 kg / 78 lbs
40'	520 Sets
MAX. WEIGHT CAPACITY	100 kg / 220 lbs



IFBR
BARBELL RACK

PRODUCT DIMENSION (L×W×H)	792×844×1380 (mm) 31.2×33.2×54.3 (in)
PRODUCT WEIGHT	43.7 kg / 96 lbs
40'	195 Sets



IFPTO
PLATE TREE-OLYMPIC

PRODUCT DIMENSION (L×W×H)	843×632×1108 (mm) 33.2×24.9×43.6 (in)
PRODUCT WEIGHT	19.5 kg / 43 lbs
40'	890 Sets

IFLEGM
LEG EXTENSION/CURL MACHINE

PRODUCT DIMENSION (L×W×H)	1215×1045×1047 (mm) 47.8×41.1×41.2 (in)
PRODUCT WEIGHT	51 kg / 112 lbs
40'	192 Sets



IFDB3
DUMBBELL RACK-3'

PRODUCT DIMENSION (L×W×H)	1079×473×677 (mm) 42.5×18.6×26.7 (in)
PRODUCT WEIGHT	29 kg / 64 lbs
40'	600 Sets



IFDB4
DUMBBELL RACK-4'

PRODUCT DIMENSION (L×W×H)	1372×473×869 (mm) 54×18.6×34.2 (in)
PRODUCT WEIGHT	35.3 kg / 78 lbs
40'	430 Sets



IFDB4A
DUMBBELL RACK-4' ATTACHMENT

PRODUCT DIMENSION (L×W×H)	1242×244×74 (mm) 48.9×9.6×2.9 (in)
PRODUCT WEIGHT	12 kg / 26 lbs
40'	1400 Sets

IF2060 2060 HOME GYM

PRODUCT DIMENSION (L×W×H)	2298×1956×2120 (mm) 90.5×77×83.5 (in)
PRODUCT WEIGHT	442.8 kg / 976 lbs
40'	40 Sets
WEIGHT STACK	2×91 kg / 200 lbs



IFLP3 HOME GYM ATTACHMENT

PRODUCT DIMENSION (L×W×H)	1673×1039×967 (mm) 65.9×40.9×38.1 (in)
PRODUCT WEIGHT	65 kg / 143 lbs
40'	220 Sets



IF1860+IFLP3



IF2060+IFLP3



IF1560 1560 HOME GYM

PRODUCT DIMENSION (L×W×H)	1905×1240×2121 (mm) 75×48.8×83.5 (in)
PRODUCT WEIGHT	223 kg / 492 lbs
40'	68 Sets
WEIGHT STACK	91 kg / 200 lbs

IF1860 1860 HOME GYM

PRODUCT DIMENSION (L×W×H)	1799×1207×2114 (mm) 70.8×47.5×83.2 (in)
PRODUCT WEIGHT	253.7 kg / 559 lbs
40'	60 Sets
WEIGHT STACK	91 kg / 200 lbs





IFFT FUNCTIONAL TRAINER

PRODUCT DIMENSION (L×W×H)	900×1800×2130 (mm) 35.4×70.9×83.9 (in)
PRODUCT WEIGHT	336 kg / 741 lbs
40'	56 Sets
WEIGHT STACK	2×91 kg / 200 lbs

IFFTOPT MULTI-SELECT STABILIZER

PRODUCT DIMENSION (L×W×H)	1075×260×1120 (mm) 42.3×10.2×44 (in)
PRODUCT WEIGHT	17.3 kg / 38 lbs IFFT+IFFTOPT



HG5 CABLE MOTION GYM

PRODUCT DIMENSION (L×W×H)	1451×1339×2132 (mm) 57.1×52.7×83.9 (in)
PRODUCT WEIGHT	202 kg / 445.4 lbs
40'	82 Sets
WEIGHT STACK	73 kg / 160 lbs

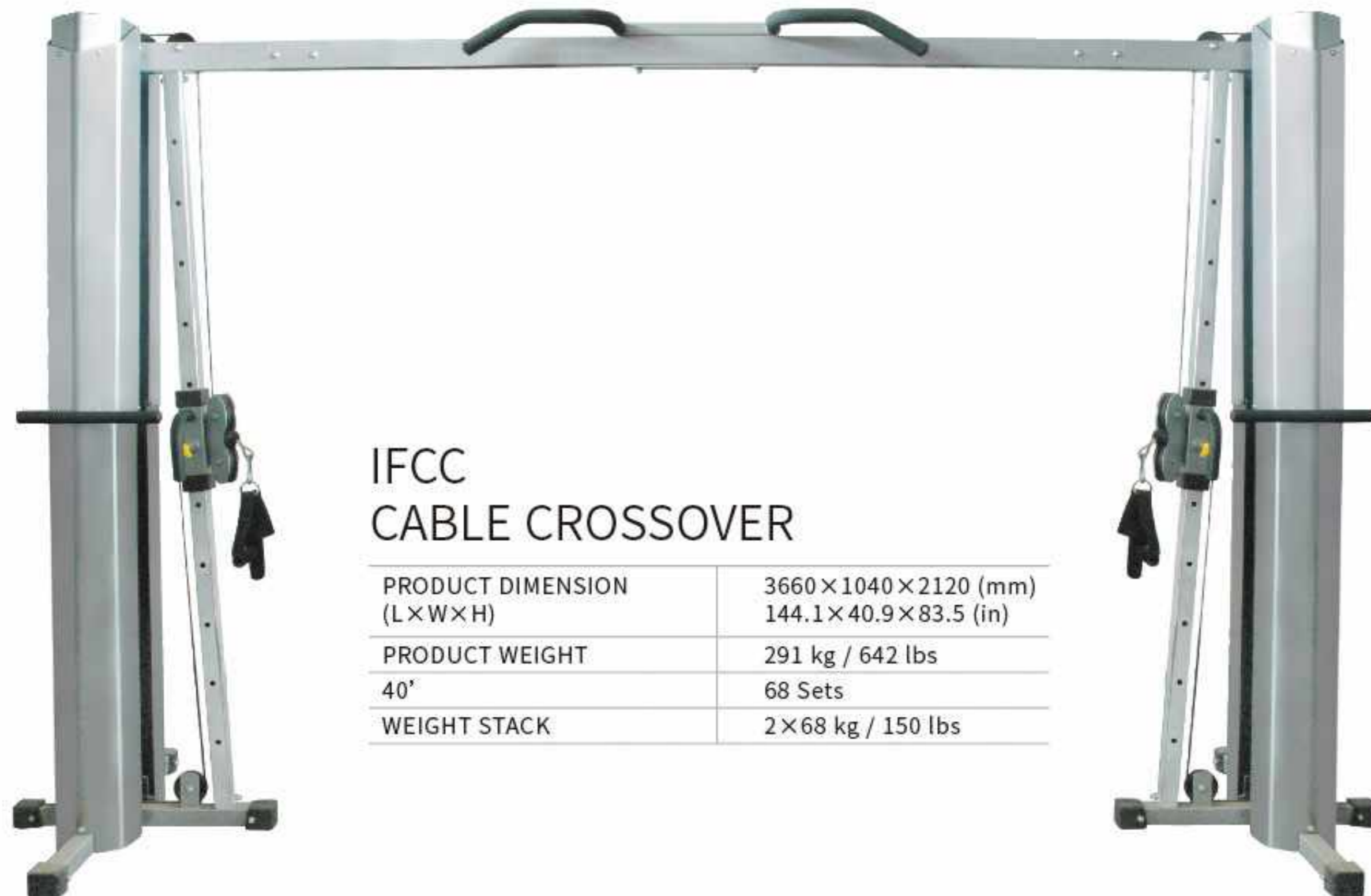

IFCC CABLE CROSSOVER

PRODUCT DIMENSION (L×W×H)	3660×1040×2120 (mm) 144.1×40.9×83.5 (in)
PRODUCT WEIGHT	291 kg / 642 lbs
40'	68 Sets
WEIGHT STACK	2×68 kg / 150 lbs



IFFI5 BENCH

PRODUCT DIMENSION (L×W×H)	1380x490x441(mm) 54.3x19.3x17.3(in)
PRODUCT WEIGHT	25.7kgs/56.7lbs
MAX WEIGHT CAPACITY	200kg/441lbs

Jungle >> >



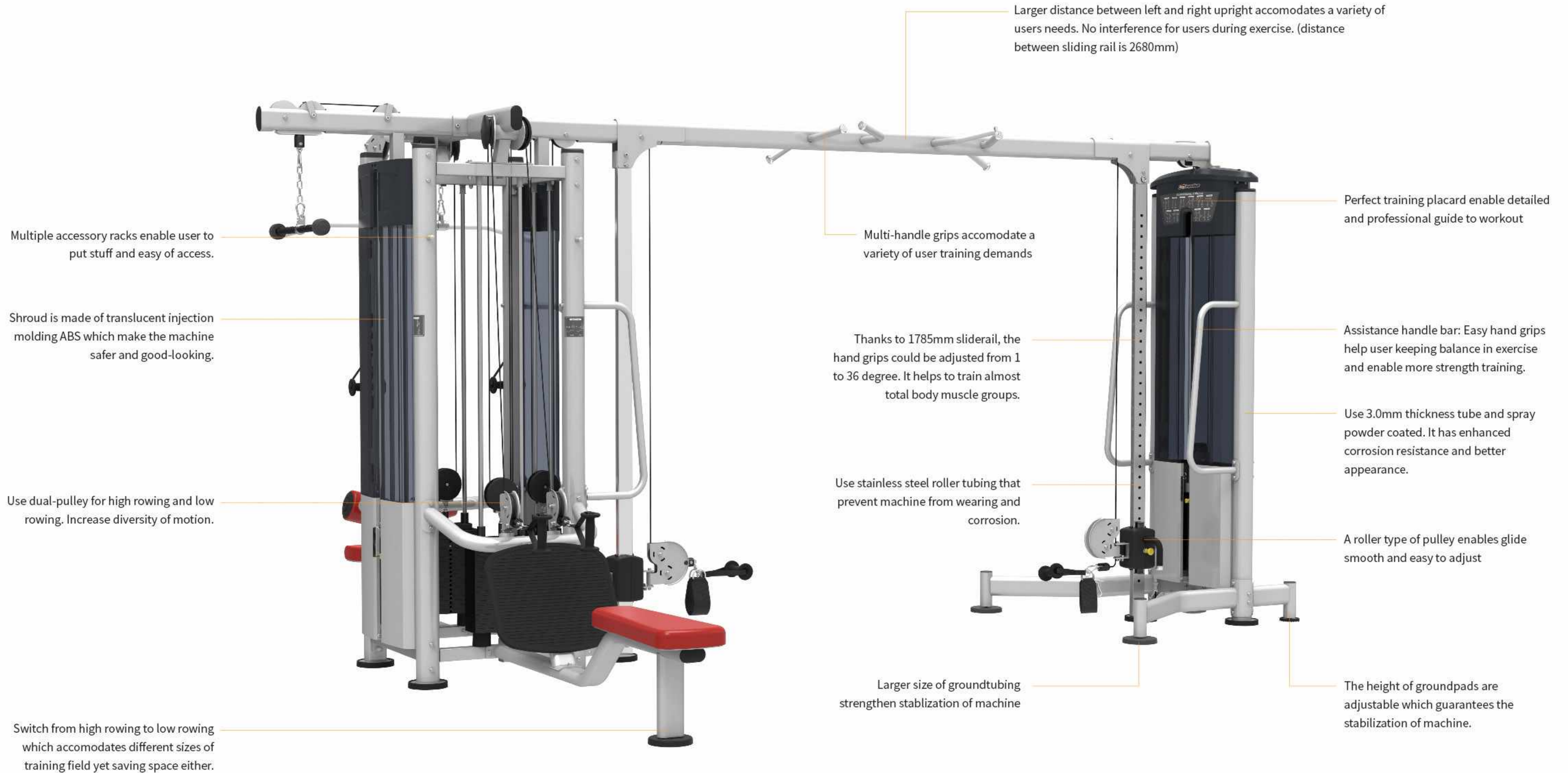

Multiple accessory racks enable user to put stuff and easy of access.

Shroud is made of translucent injection molding ABS which make the machine safer and good-looking.

Use dual-pulley for high rowing and low rowing. Increase diversity of motion.

Switch from high rowing to low rowing which accomodates different sizes of training field yet saving space either.

Larger distance between left and right upright accomodates a variety of users needs. No interference for users during exercise. (distance between sliding rail is 2680mm)

Multi-handle grips accomodate a variety of user training demands

Thanks to 1785mm sliderail, the hand grips could be adjusted from 1 to 36 degree. It helps to train almost total body muscle groups.

Use stainless steel roller tubing that prevent machine from wearing and corrosion.

Larger size of groundtubing strengthen stablization of machine

Perfect training placard enable detailed and professional guide to workout

Assistance handle bar: Easy hand grips help user keeping balance in exercise and enable more strength training.

Use 3.0mm thickness tube and spray powder coated. It has enhanced corrosion resistance and better appearance.

A roller type of pulley enables glide smooth and easy to adjust

The height of groundpads are adjustable which guarantees the stabilization of machine.



IT9525 ADJUSTABLE HI/LO PULLEY

PRODUCT DIMENSION (LxWxH)	1450x1245x2350(mm) 57.1x49.0x92.5(in)
PRODUCT WEIGHT	93.9Kg/206.58lbs (TBD)

* TRANSPARENT SHROUD IS OPTIONAL.



IT9530 DUAL ADJUSTABLE PULLEY

PRODUCT DIMENSION (LxWxH)	1620x1370x2270(mm) 63.8x54.0x59.4(in)
PRODUCT WEIGHT	165kg/363lbs (TBD)



IT9527 4 STACK MULTI-STATION

PRODUCT DIMENSION (LxWxH)	3489x1968x2382(mm) 137.4x77.5x93.8(in)
PRODUCT WEIGHT	295Kg/649lbs (TBD)

* TRANSPARENT SHROUD IS OPTIONAL.



IT9527OPT CABLE CROSSOVER-TRADITIONAL

PRODUCT DIMENSION (LxWxH)	2824x222x483(mm) 111.2x8.74x19.0(in)
PRODUCT WEIGHT	29Kg/63.8lbs (TBD)



IT9525+IT9525+IT9527OPT

PRODUCT DIMENSION (LxWxH)	4196 × 1436 × 2360(mm) 165.2 × 56.5 × 92.9(in)
------------------------------	---

IT9525+IT9527+IT9527OPT

PRODUCT DIMENSION (LxWxH)	5089 × 3489 × 2380(mm) 200.4 × 137.4 × 93.7(in)
------------------------------	--



IT9527+IT9527+IT9527OPT

PRODUCT DIMENSION (LxWxH)	5982 × 3489 × 2380(mm) 235.5 × 137.4 × 93.7(in)
------------------------------	--



* TRANSPARENT SHROUD IS OPTIONAL.



IF8125 ADJUSTABLE HI / LO PULLEY

PRODUCT DIMENSION (L×W×H)	1304×979×2494 (mm) 51.3×38.5×98.2 (in)
PRODUCT WEIGHT	96 kg / 212 lbs
40'	108 Sets

IF8127 4 STACK MULTI-STATION

PRODUCT DIMENSION (L×W×H)	3688×1988×2501 (mm) 145.2×78.3×98.5 (in)
PRODUCT WEIGHT	258.6 kg / 570 lbs
40'	48 Sets



IF8127OPT CABLE CROSSOVER-TRADITIONAL

PRODUCT DIMENSION (L×W×H)	2538×498×200 (mm) 99.9×19.6×7.9 (in)
PRODUCT WEIGHT	21.5 kg / 47 lbs
40'	526 Sets



CABLE CROSSOVER

IF8125+IF8125+IF8127OPT

PRODUCT DIMENSION (L×W×H)	3880x1295x2494(mm) 153x51x98(in)
------------------------------	-------------------------------------

5 STACK MULTI-STATION

IF8125+IF8127+IF8127OPT

PRODUCT DIMENSION (L×W×H)	5006x3686x2498(mm) 197x145x98(in)
------------------------------	--------------------------------------



8 STACK MULTI-STATION

IF8127+IF8127+IF8127OPT

PRODUCT DIMENSION (L×W×H)	6071x4321x2498(mm) 239x170x98(in)
------------------------------	--------------------------------------

ES3000 3 STACK MULTI-STATION

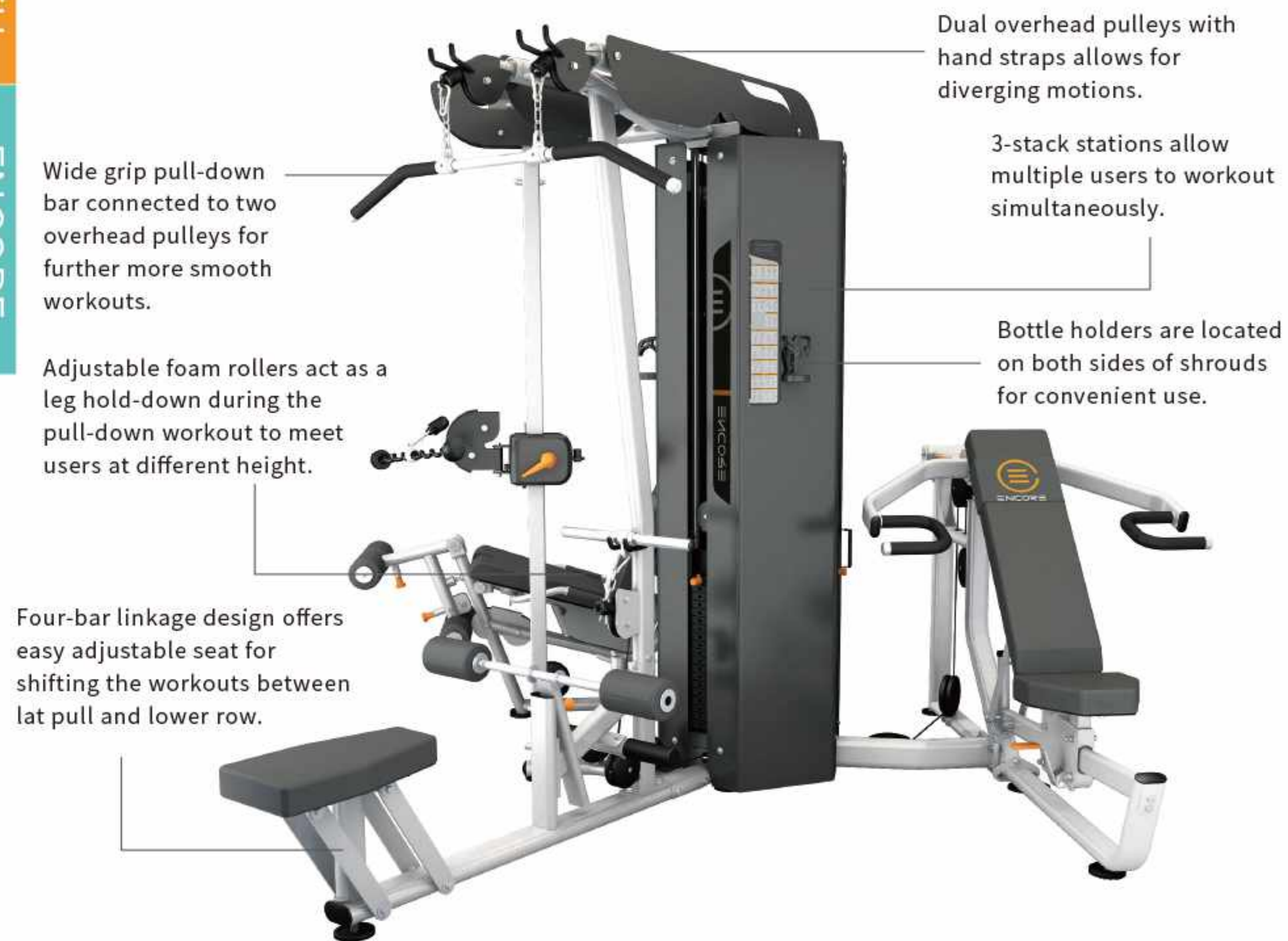

Dual overhead pulleys with hand straps allows for diverging motions.

3-stack stations allow multiple users to workout simultaneously.

Bottle holders are located on both sides of shrouds for convenient use.

Wide grip pull-down bar connected to two overhead pulleys for further more smooth workouts.

Adjustable foam rollers act as a leg hold-down during the pull-down workout to meet users at different height.

Four-bar linkage design offers easy adjustable seat for shifting the workouts between lat pull and lower row.

Product Dimension (L×W×H)	2705x2455x2148(mm) 106.50x96.65x84.57(in)
Product Weight	573kg
Stacks Weight	91kgx3 (200lbsx3)
OPT Weight	26.5kg

ES3000 OPT HI-LO PULLEY ATTACHMENT

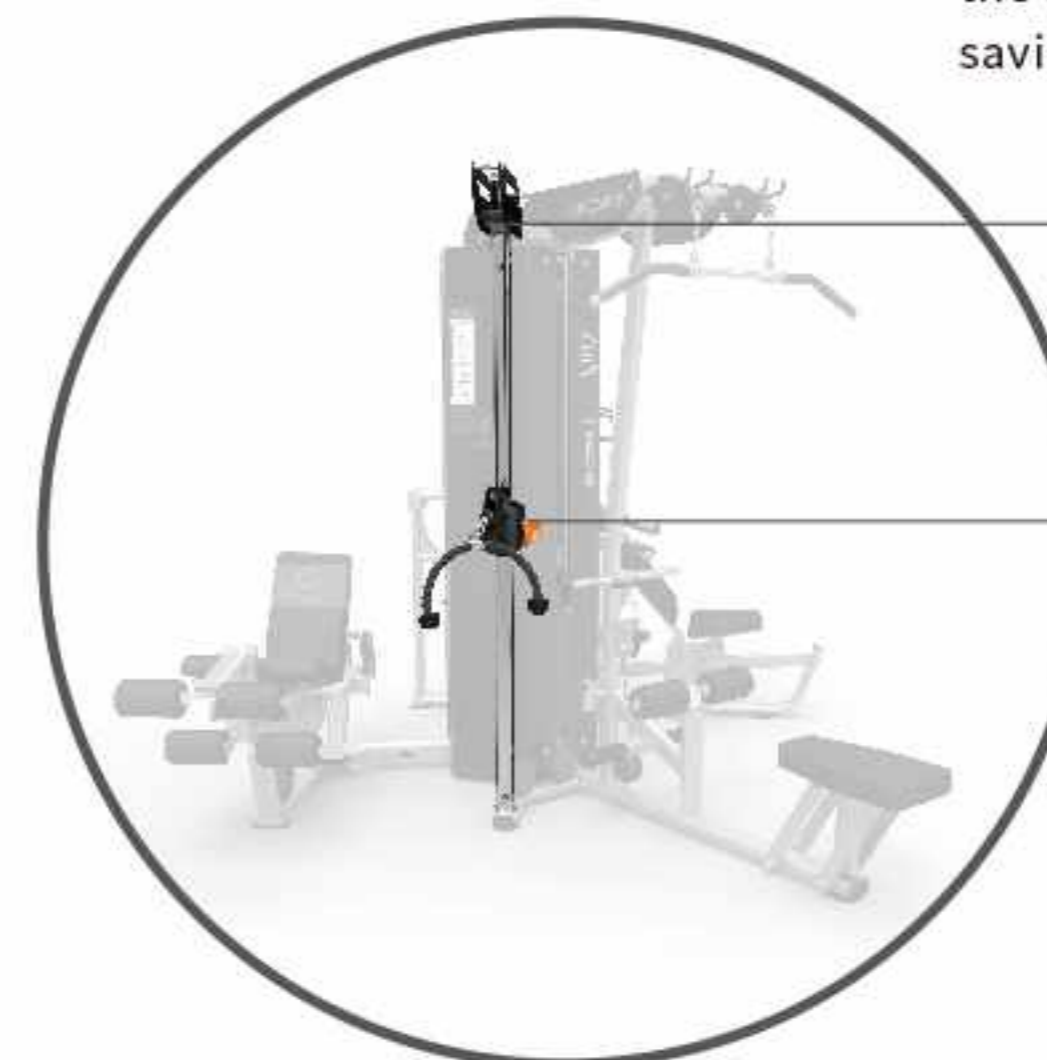

Quick installation, shares the stack with lat pull for saving space and cost.

31 vertical pulley positions for a large variety of different exercises.



Excellent structural design, easy & quick adjustment offers dynamic workout like chest press, incline press and shoulder press which meet various muscle groups training.



Adjustable handle is conveniently located for easy access.

Excellent structural design, easy & quick adjustment seat is for prone leg curls or leg extension exercises which satisfy various muscle groups.

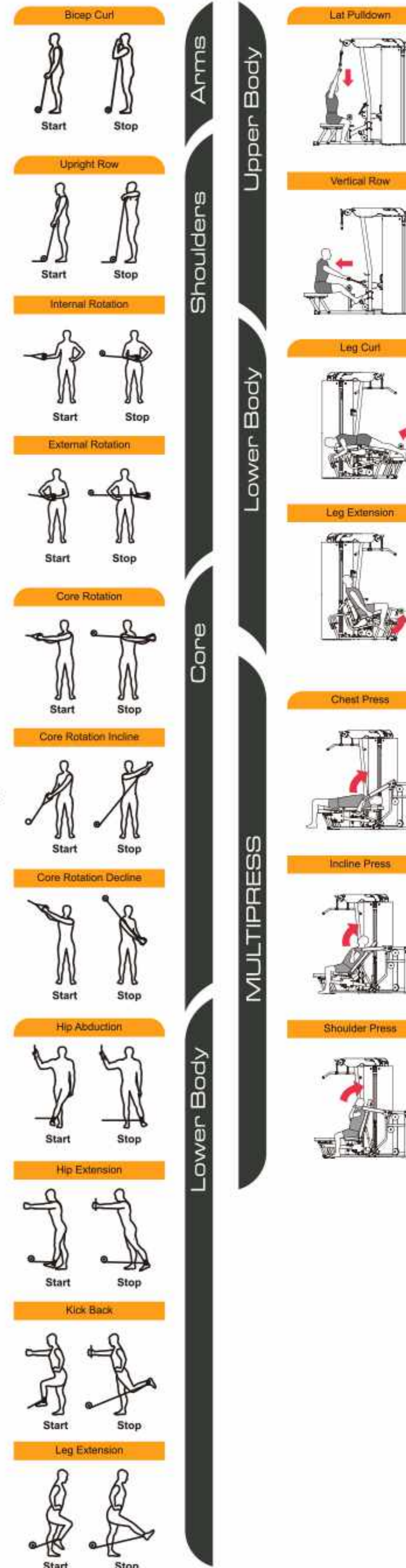

ES9030 DUAL ADJUSTABLE PULLEY ES7011 BENCH



Chin-up/pull-up bar with ergonomic bends for regular grip, wide grip and reverse grip exercises.

31 vertical pulley positions for a large variety of different exercises.

With accessories as lat strap, long bar retractable strap, leg ext/curl strap and tricep rope, DAP offers users dynamic and various workouts.

Multi-position bench offers 5 upright/incline positions for back pad and 3 position for seat, which satisfies various workout experience.

The over-sized feet would stabilize the users during certain workouts like tricep extension.

Conveniently located iPad holder allows user to watch online training videos during the workouts, over-sized bottle holder is within reach.



Fold away bench for easy storage and space saving



ES9030(Long Shroud)

Product Dimension (L×W×H)	1734x1123x2150(mm) 68.27x44.21x84.65(in)
Product Weight	149.5kg/328.9lbs
Stacks Weight	77kgx2 (170lbsx2)



ES9030(Short Shroud)

Product Dimension (L×W×H)	1734x1123x2150(mm) 68.27x44.21x84.65(in)
Product Weight	121.5kg/267.3lbs
Stacks Weight	77kgx2 (170lbsx2)



ES7011

Product Dimension (L×W×H)	1440x525x490(mm) 56.69x20.67x19.29(in)
Product Weight	34.3kg

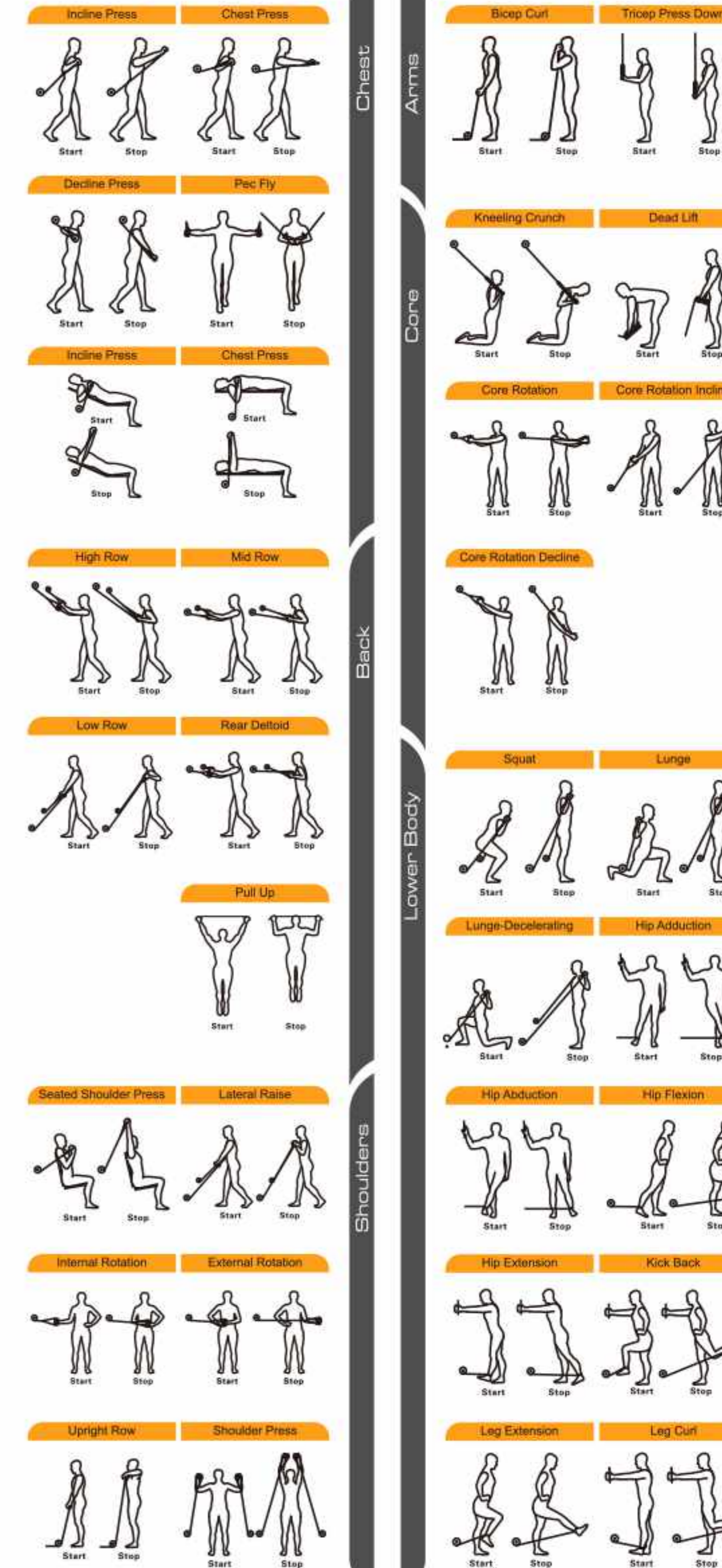

RE-LIFE

Hydraulic Strength Training Equipment



RL Line >>>

STRENGTH

RL

In the face of such a busy pace of life, Impulse timely put forward the concept of 'light fitness', and explored how to exercise to 'win more with less effort', integrate exercise into your daily life and make it a wonderful enjoyment. Unlike conventional strength equipment, 'light fitness tends to listen to the voice of the heart.

Impulse RE-LIFE light fitness series is tailored for the urban white-collar workers and young women who love sports, as well as small studios and community gyms. Impulse named the series after RE-LIFE implying that customers can regain the vitality of the body and rebuild the quality of life by using this series of products.

The RE-LIFE series complements any traditional fitness scenario, suitable for users from almost all ages and fitness levels.

8+X Flexible combinations, more possibilities

RE-LIFE series consists of 8 sets of hydraulic resistance training equipment which can be used for bidirectional constant speed operation and 1 set of stretching machine. 8 sets of hydraulic resistance training equipment can realize the function of 15 kinds of traditional strength equipment, and the stretching machine is helpful before and after exercise. Alternatively, depending on the user's needs, the stretching machine can be replaced with a BOSU ball for balance training, cardio pedals, or a HIIT SKI&ROW* or ULTRA BIKE*. Users of different ages and physical qualities can find their own training methods through the flexible combination of 8+X.

* SKI&ROW and ULTRA BIKE are products of Impulse.



Ultimate User Experience Design Driven Products Environment Friendly



The dual-position handle design ensures that the user always finds the perfect posture.



The selection of upholstery is soft, comfortable and elastic, making it more skin-friendly during training and reducing wear. The multifunctional holder allows you to take water cup or mobile phone at your fingertips.



Adjustable hydraulic resistance makes adjustment more refined with eye-catching knob design.

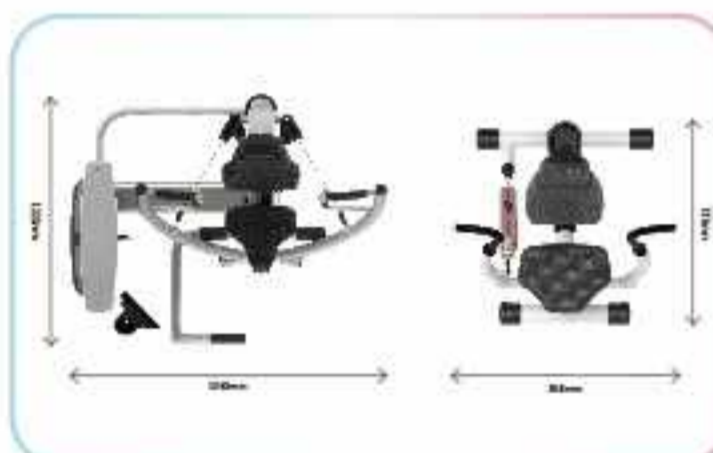

Concise modeling design can save half of the storage and transportation space compared with conventional equipment, the built-in transport wheel design makes it easier to move.



The resistance adapts itself and can stop the movement at any time to reduce the injury risk. In addition, the integrated stable adjusting device can easily adjust the horizontal stability of the product.



Optional painting and upholstery color.
(Terms and conditions applied)



RL8101
CHEST PRESS/ROW

PRODUCT DIMENSION (L×W×H)	818 × 737 × 1260 (mm) 32.2 × 29.0 × 49.6 (in)
---------------------------	--



RL8102
OVERHEAD PRESS/PULLDOWN

PRODUCT DIMENSION (L×W×H)	1120 × 1000 × 1296 (mm) 44.1 × 39.4 × 50.0 (in)
---------------------------	--



RL8103 BICEPS CURL
TRICEPS EXTENSION

PRODUCT DIMENSION (L×W×H)	1178 × 736 × 859 (mm) 46.4 × 19.0 × 33.8 (in)
---------------------------	--



RL8104
PEC FLY/REAR DELTOID

PRODUCT DIMENSION (L×W×H)	1139 × 895 × 1286 (mm) 44.8 × 35.2 × 50.6 (in)
---------------------------	---



RL8105
LEG EXTENSION/LEG CURL

PRODUCT DIMENSION (L×W×H)	1174 × 830 × 1260 (mm) 46.2 × 32.7 × 49.6 (in)
---------------------------	---



RL8107
Ab CRUNCH/BACK EXTENSION

PRODUCT DIMENSION (L×W×H)	1097 × 842 × 1165 (mm) 43.2 × 33.1 × 45.9 (in)
---------------------------	---



RL8108
HIP ABDUCTION/ADDUCTION

PRODUCT DIMENSION (L×W×H)	1122 × 737 × 1260 (mm) 44.2 × 29.0 × 49.6 (in)
---------------------------	---



RL8110
LEG PRESS

PRODUCT DIMENSION (L×W×H)	1737 × 737 × 1260 (mm) 68.4 × 29.0 × 49.6 (in)
---------------------------	---



RL8106
STRETCH

PRODUCT DIMENSION (L×W×H)	1174 × 830 × 1260 (mm) 46.2 × 32.7 × 49.6 (in)
---------------------------	---



SL Line >>>

Easy to use, neat appearance, the SL line is a high quality commercial plate loaded series. The user-friendly design makes working out more simple, efficient, comfortable and satisfying.

Tubing: thickness range from 2.5 mm to 3mm, 50mmx100mm tubing, electro-welded to maximum integrity.

Color: black and red (Other colors are optional based on customer requirements)

Finish: Electrostatic powder-coated and heat cured after adhesiveness enhancement pre-treatment for superior durability



Compact - space efficient design requires minimal floor space.

Pad total thickness is 70mm.

Easy-to-use, flexible adjustments allow for optimal exercise positions.





SL7001 CHEST PRESS

PRODUCT DIMENSION (L×W×H)	1937×1370×1717 (mm) 76.3×53.9×67.6 (in)
PRODUCT WEIGHT	163 kg / 359 lbs
40'	70 Sets
MAX. WEIGHT CAPACITY	300 Kg / 660 lbs



SL7002 PULLDOWN

PRODUCT DIMENSION (L×W×H)	1482×1489×1967 (mm) 58.3×58.6×77.4 (in)
PRODUCT WEIGHT	164 kg / 362 lbs
40'	81 Sets
MAX. WEIGHT CAPACITY	300 kg / 660 lbs



SL7004 LOW ROW

PRODUCT DIMENSION (L×W×H)	1761×1457×1652 (mm) 69.3×57.4×65 (in)
PRODUCT WEIGHT	167.5 kg / 369 lbs
40'	69 Sets
MAX. WEIGHT CAPACITY	300 kg / 660 lbs



SL7005 INCLINE CHEST PRESS

PRODUCT DIMENSION (L×W×H)	1900×1523×1779 (mm) 74.8×60×70 (in)
PRODUCT WEIGHT	183.5 kg / 405 lbs
40'	72 Sets
MAX. WEIGHT CAPACITY	300 kg / 660 lbs



SL7003 SHOULDER PRESS

PRODUCT DIMENSION (L×W×H)	1558×1818×1487 (mm) 61.3×71.6×58.5 (in)
PRODUCT WEIGHT	171 kg / 377 lbs
40'	89 Sets
MAX. WEIGHT CAPACITY	300 kg / 660 lbs



SL7006 LEG PRESS

PRODUCT DIMENSION (L×W×H)	2226×1421×1419 (mm) 87.6×55.9×55.9 (in)
PRODUCT WEIGHT	192.5 kg / 424 lbs
40'	65 Sets
MAX. WEIGHT CAPACITY	400 kg / 880 lbs





SL7007 ROW

PRODUCT DIMENSION (L×W×H)	1815×1500×1334 (mm) 71.5×59.1×52.5 (in)
PRODUCT WEIGHT	157 kg / 346 lbs
40'	87 Sets
MAX. WEIGHT CAPACITY	300 kg / 660 lbs



SL7008 REAR KICK

PRODUCT DIMENSION (L×W×H)	1680×1229×1636 (mm) 66.1×48.4×64.4 (in)
PRODUCT WEIGHT	142kg / 313lbs
40'	82 Sets
MAX. WEIGHT CAPACITY	150kg / 330lbs

SL7017 SEATED CALF RAISE

PRODUCT DIMENSION (L×W×H)	1475×765×845 (mm) 58×30.1×33.3 (in)
PRODUCT WEIGHT	56 kg / 123 lbs
40'	174 Sets
MAX. WEIGHT CAPACITY	150 kg / 330 lbs



SL7013 GLUTE HAM BENCH

PRODUCT DIMENSION (L×W×H)	1562×914×1477 (mm) 61.5×36×58.1 (in)
PRODUCT WEIGHT	70 kg / 154 lbs
40'	105 Sets



SL7019 INCLINE ROW

PRODUCT DIMENSION (L×W×H)	1960×1020×1253 (mm) 77.2×40.2×49.3 (in)
PRODUCT WEIGHT	89 kg / 196 lbs
40'	97 Sets
MAX. WEIGHT CAPACITY	150 kg / 330 lbs





SL7021 HACK SQUAT

PRODUCT DIMENSION (L×W×H)	2205×1880×1285 (mm) 86.8×74×50.6 (in)
PRODUCT WEIGHT	236kg / 519lbs
MAX. WEIGHT CAPACITY	400kg / 880lbs



SL7023 BICEP CURL

PRODUCT DIMENSION (L×W×H)	1403×1045×1200 (mm) 55.2×41.1×47.2 (in)
PRODUCT WEIGHT	112kg / 246lbs
40'	96 Sets
MAX. WEIGHT CAPACITY	120 kg / 264 lbs



SL7024 TRICEP DIP

PRODUCT DIMENSION (L×W×H)	1733×1580×1202 (mm) 68.2×62.2×47.3 (in)
PRODUCT WEIGHT	166kg / 365lbs
MAX. WEIGHT CAPACITY	300 kg / 660 lbs



SL7020 45 LEG PRESS

PRODUCT DIMENSION (L×W×H)	2499×1879×1544 (mm) 98.4×74×60.8 (in)
PRODUCT WEIGHT	249kg / 548lbs
40'	58 Sets
MAX. WEIGHT CAPACITY	450kg / 990lbs



SL7025 LEG EXTENSION

PRODUCT DIMENSION (L×W×H)	1270×1690×1005 (mm) 50×66.5×39.6 (in)
PRODUCT WEIGHT	131kg / 288lbs
MAX. WEIGHT CAPACITY	300 kg / 660 lbs



SL7026 LEG CURL

PRODUCT DIMENSION (L×W×H)	1403×1045×1200 (mm) 55.2×41.1×47.2 (in)
PRODUCT WEIGHT	136kg / 299lbs
MAX. WEIGHT CAPACITY	120 kg / 264 lbs



SL7032 STANDING CALF RAISE

PRODUCT DIMENSION (L×W×H)	1615×1375×1730(mm) 63.6×54.1×68.1 (in)
PRODUCT WEIGHT	175 kg/385 lbs(TBD)
MAX. WEIGHT CAPACITY	300 kg/660 lbs



SL7034 SQUAT

PRODUCT DIMENSION (L×W×H)	2260x1260x1800 (mm) 88.9x49.6x70.9 (in)
PRODUCT WEIGHT	300 kg/660 lbs
MAX. WEIGHT CAPACITY	400 kg/880 lbs



SL7038 TOTAL HIP

PRODUCT DIMENSION (LxWxH)	1618x1608x1106 (mm) 63.7x63.3x43.5 (in)
PRODUCT WEIGHT	150kg(TBD)



SL7039 STANDING PRESS

PRODUCT DIMENSION (LxWxH)	2170x1999x2133 (mm) 85.4x78.7x84.0 (in)
PRODUCT WEIGHT	180kg(TBD)



SL7036 ABDOMINAL

PRODUCT DIMENSION (L×W×H)	1623×1267×1642 (mm) 63.9×49.9×64.6 (in)
PRODUCT WEIGHT	120 kg/264 lbs(TBD)
MAX. WEIGHT CAPACITY	120 kg/264 lbs



SL7040 LOWER LIMBS

PRODUCT DIMENSION (LxWxH)	1668x1699x636 (mm) 65.7x66.9x25.0 (in)
PRODUCT WEIGHT	130kg(TBD)





SL7009 POWER RACK

PRODUCT DIMENSION (L×W×H)	2031×1499×2278 (mm) 80×59×89.7 (in)
PRODUCT WEIGHT	200 kg / 441 lbs
40'	82 Sets

SL7009OPT
WEIGHT PLATE RACK OPTION

PRODUCT DIMENSION (L×W×H)	1674×717×2199 (mm) 65.9×28.2×86.6 (in)
PRODUCT WEIGHT	63.5 kg / 140 lbs
40'	144 Sets



SL7028 FLAT BENCH PRESS

PRODUCT DIMENSION (L×W×H)	1910x1738x1315 (mm) 75.2x68.4x51.8 (in)
PRODUCT WEIGHT	112 kg/246 lbs
MAX. WEIGHT CAPACITY	300 kg/660 lbs



SL7029 INCLINE BENCH PRESS

PRODUCT DIMENSION (L×W×H)	2059x1738x1496 (mm) 81.1x68.4x58.9 (in)
PRODUCT WEIGHT	113 kg/249 lbs
MAX. WEIGHT CAPACITY	300 kg/660 lbs



SL7014 HALF POWER RACK

PRODUCT DIMENSION (L×W×H)	1390×1747×2442 (mm) 54.7×68.8×96.1 (in)
PRODUCT WEIGHT	153 kg / 337 lbs
40'	108 Sets



SL7015 FULL POWER RACK

PRODUCT DIMENSION (L×W×H)	1966×1747×2442 (mm) 77.4×68.8×96.1 (in)
PRODUCT WEIGHT	216 kg / 476 lbs
40'	83 Sets



SL7030 DECLINE BENCH PRESS

PRODUCT DIMENSION (L×W×H)	2188x1738x1315 (mm) 86.1x68.4x51.8 (in)
PRODUCT WEIGHT	104 kg/229 lbs
MAX. WEIGHT CAPACITY	300 kg/660 lbs



SL7031 SHOULDER BENCH PRESS

PRODUCT DIMENSION (L×W×H)	1719x1261x1920(mm) 67.7x49.6x75.6(in)
PRODUCT WEIGHT	150 kg/330 lbs
MAX. WEIGHT CAPACITY	400 kg/880 lbs



SL7011 FID BENCH

PRODUCT DIMENSION (L×W×H)	1350×670×1350 (mm) 53.1×26.4×53.1 (in)
PRODUCT WEIGHT	44 kg / 97 lbs
40'	252 Sets



SL7012 FI BENCH

PRODUCT DIMENSION (L×W×H)	1550×670×1350 (mm) 61×26.4×53.1 (in)
PRODUCT WEIGHT	47 kg / 104 lbs
40'	252 Sets



SL7010 PLATE RACK

PRODUCT DIMENSION (L×W×H)	891×628×1228 (mm) 35.1×24.7×48.3 (in)
PRODUCT WEIGHT	44 kg / 97 lbs
40'	242 Sets



SL7027 BARBELL RACK

PRODUCT DIMENSION (L×W×H)	950×910×1612 (mm) 37.4×35.8×63.5 (in)
PRODUCT WEIGHT	73 kg / 161 lbs
40'	112 Sets



SL7018 ARM CURL

PRODUCT DIMENSION (L×W×H)	1140x860x1020 (mm) 44.9x33.9x40.2 (in)
PRODUCT WEIGHT	65kgs/143lbs
MAX.WEIGHT CAPACITY	300kgs/661.4lbs



SL7022 UTILITY BENCH

PRODUCT DIMENSION (L×W×H)	1191×630×822 (mm) 46.9×24.8×32.4 (in)
PRODUCT WEIGHT	26.8 kg / 59 lbs
40'	253 Sets



SL7035 FLAT BENCH

PRODUCT DIMENSION (L×W×H)	1281x630x425 (mm) 50.4x24.8x16.7 (in)
PRODUCT WEIGHT	25.5 kg/56 lbs
MAX. WEIGHT CAPACITY	300 kg/660 lbs

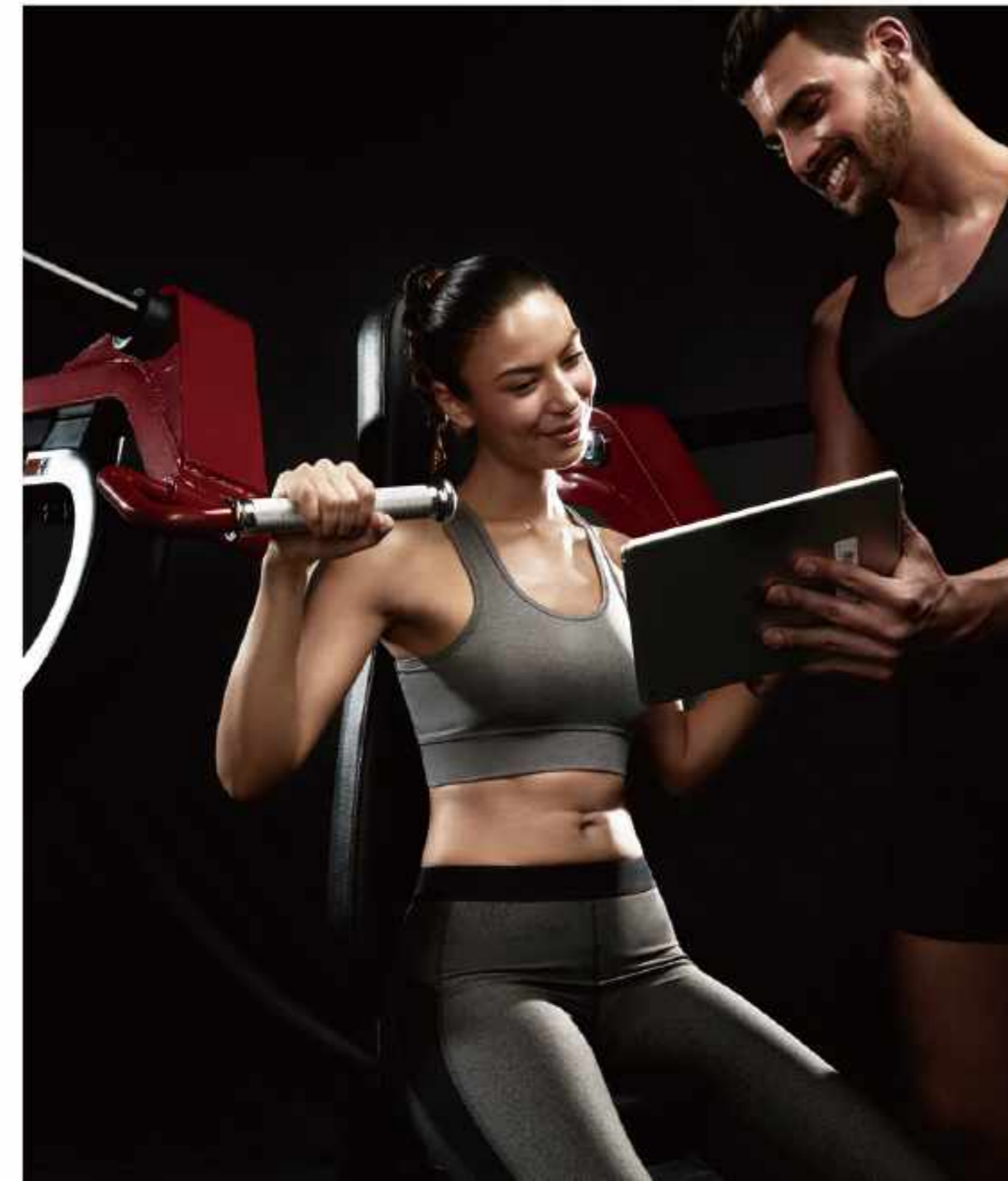

SL7016 DUMBBELL RACK

PRODUCT DIMENSION (L×W×H)	2260×760×740 (mm) 89.0×29.9×29.1 (in)
PRODUCT WEIGHT	76 kg/167.2 lbs
40'	240 Sets
MAX. WEIGHT CAPACITY	700 kg/ 1540 lbs



SL7041 SUPER OLYMPIC BENCH

PRODUCT DIMENSION (LxWxH)	2410x1743x1622 (mm) 94.9x68.6x63.9 (in)
PRODUCT WEIGHT	141.3kg/311.5lbs

SL7042
MAGIC RACK/SMITH MACHINE

PRODUCT DIMENSION (LxWxH)	2315x2241x2391 (mm) 91.1x88.2x94.1 (in)
PRODUCT WEIGHT	313.4kg/690.9lbs

SL7045
VERTICAL KNEE RAISE/DIP STAND

PRODUCT DIMENSION (LxWxH)	1189x765x1357 (mm) 46.8x30.1x53.4 (in)
PRODUCT WEIGHT	74.3kg/163.8lbs



SL7045OPT CHIN-UP AND DIP

PRODUCT DIMENSION (LxWxH)	1189x1157x2388 (mm) 46.8x45.6x94.0 (in)
PRODUCT WEIGHT	31.5kg/69.4lbs



SL7043 MULTI AB BENCH

PRODUCT DIMENSION (LxWxH)	1722x630x912 (mm) 67.8x24.8x35.9 (in)
PRODUCT WEIGHT	54kg/119lbs



SL7044 STRETCH

PRODUCT DIMENSION (LxWxH)	1567x630x1263 (mm) 61.7x24.8x49.7 (in)
PRODUCT WEIGHT	50kg/110.2lbs

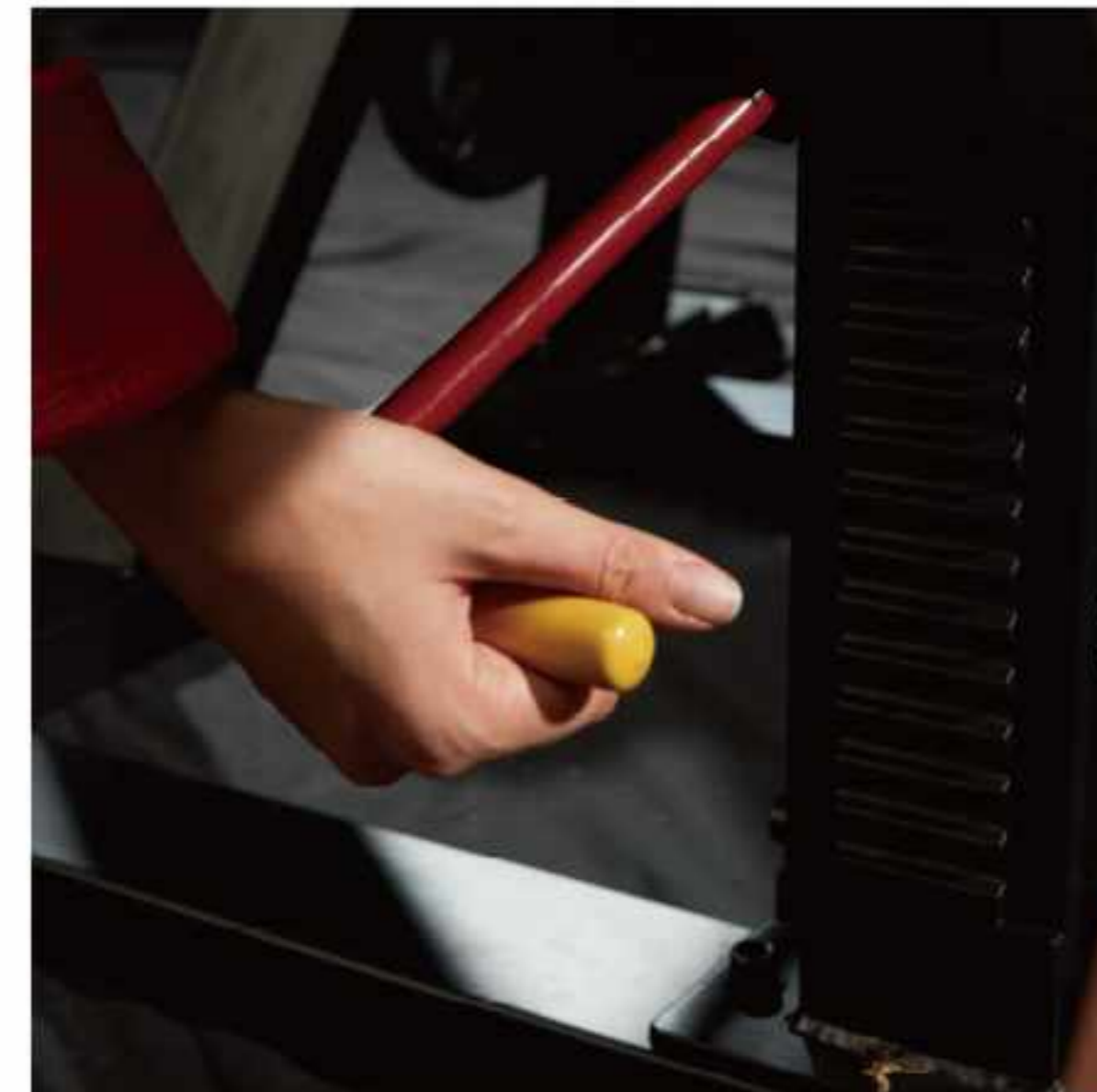

SL7047 MULTI HYPER EXTENSION

PRODUCT DIMENSION (LxWxH)	1340x947x765 (mm) 52.8x37.3x30.1 (in)
PRODUCT WEIGHT	55.2kg/121.7lbs

SE Line >>>

STRENGTH

SE

Half Rack and Power Rack are able to be connected left or right and extended infinitely, along with optional storage cart, help users to achieve their training goals by all in one combination. It also improves utilization of space.

76.2mm square tube with 4.5mm thickness to achieve a maximum training weight of 900lbs.

We upgrade the storage bars from PVC to stainless steel, which is more high-end and ensures rust protection and service life. Meanwhile, the slightly inclined storage bars also ensure the stability of weight plate storage.

The use of thickened steel increases the stability of the product.

STERLING ELITE is perfect for heavy-user facilities; it not only can help user with training base to go to the next level, but also helps athletes achieve the results they seek in ways of more professional, more functional and customizable.

15/16 adjustable height positions(535mm~2057mm/495mm~2018mm from the ground) for J hooks and safety bumpers.

The ABS safety bar is updated to TPU material, which greatly extends the service life due to its wear resistance, and the TPU has better vibration absorption also provides a better use experience.











A rich variety of functionality and professional optional accessories provide numerous training opportunities for a wide range of exercisers and also allow training stadium to collect easily in the idle condition.

The platform is 50 millimeters thick, which is made by hardwood floor plus rubber mat, and fixed with all metal frame to ensure that the platform is firm and reliable.



STRENGTH

SE

	Shape	Package	Product Dimension
HALF RACK		SE5001 HALF RACK SE5011 STAND-SINGLE STORAGE	1848×1378×2476(mm) 72.8×54.3×97.5(in)
HALF RACK+PLATFORM		SE5001 HALF RACK SE5011 STAND-SINGLE STORAGE SE5031 PLATFORM	2445×3547×2476 (mm) 96.3×139.6×97.5(in)
POWER RACK		SE5002 POWER RACK SE5011 STAND-SINGLE STORAGE	1848×2045×2476 (mm) 72.8×80.5×97.5(in)
POWER RACK+PLATFORM		SE5002 POWER RACK SE5011 STAND-SINGLE STORAGE SE5032 PLATFORM	2445×4214×2476(mm) 96.3×165.9×97.5(in)
DOUBLE HALF RACK		2× SE5001 HALF RACK 1× SE5012 COMBO STORAGE-SINGLE	1482×2679×2476(mm) 58.3×105.5×97.5(in)
COMBO POWER/HALF RACK		1× SE5001 HALF RACK 1× SE5012 COMBO STORAGE-SINGLE 1× SE5002 POWER RACK	1482×3346×2476(mm) 58.3×131.7×97.5(in)
DOUBLE POWER RACK		2× SE5002 POWER RACK 1× SE5012 COMBO STORAGE-SINGLE	1482×4012×2476(mm) 58.3×158.0×97.5(in)
HALF RACK + CONNECTOR + HALF RACK		2× SE5001 HALF RACK 2× SE5011 STAND-SINGLE STORAGE 1× SE5025 BALL STORAGE CONNECTOR 1× SE5024 FREE STORAGE CONNECTOR 1× SE5023 BUMPER PLATE STORAGE CONNECTOR 1× SE5022 RACK CONNECTOR-THICK STRAIGHT	4961×1555×2476(mm) 195.3×61.2×97.5(in)
HALF RACK+ CONNECTOR +POWER RACK		1× SE5001 HALF RACK 1× SE5002 POWER RACK 2× SE5011 STAND-SINGLE STORAGE 1× SE5025 BALL STORAGE CONNECTOR 1× SE5024 FREE STORAGE CONNECTOR 1× SE5023 BUMPER PLATE STORAGE CONNECTOR 1× SE5021 RACK CONNECTOR-MULTI-GRIP	4961×2222×2476(mm) 195.3×87.5×97.5(in)
HALF RACK+ CONNECTOR +PLATFORM +POWER RACK		1× SE5001 HALF RACK 1× SE5002 POWER RACK 2× SE5011 STAND-SINGLE STORAGE 1× SE5025 BALL STORAGE CONNECTOR 1× SE5024 FREE STORAGE CONNECTOR 1× SE5023 BUMPER PLATE STORAGE CONNECTOR 1× SE5022 RACK CONNECTOR-THICK STRAIGHT 1× SE5031 PLATFORM	5273×3725×2476(mm) 207.6×146.7×97.5(in)
3× HALF RACK+ CONNECTOR +POWER RACK+PLATFORM		3× SE5001 HALF RACK 1× SE5002 POWER RACK 2× SE5012 COMBO STORAGE-SINGLE 1× SE5025 BALL STORAGE CONNECTOR 1× SE5024 FREE STORAGE CONNECTOR 1× SE5023 BUMPER PLATE STORAGE CONNECTOR 1× SE5021 RACK CONNECTOR-MULTI-GRIP 1× SE5031 PLATFORM	5273×4848×2476(mm) 207.6×190.9×97.5(in)



SE5001 HALF RACK

PRODUCT DIMENSION (L×W×H)	1338×1301×2476 (mm) 52.7×51.2×97.5 (in)
PRODUCT WEIGHT	118.3Kg



SE5002 POWER RACK

PRODUCT DIMENSION (L×W×H)	1338×1968×2476(mm) 52.7×77.5×97.5 (in)
PRODUCT WEIGHT	193.3Kg

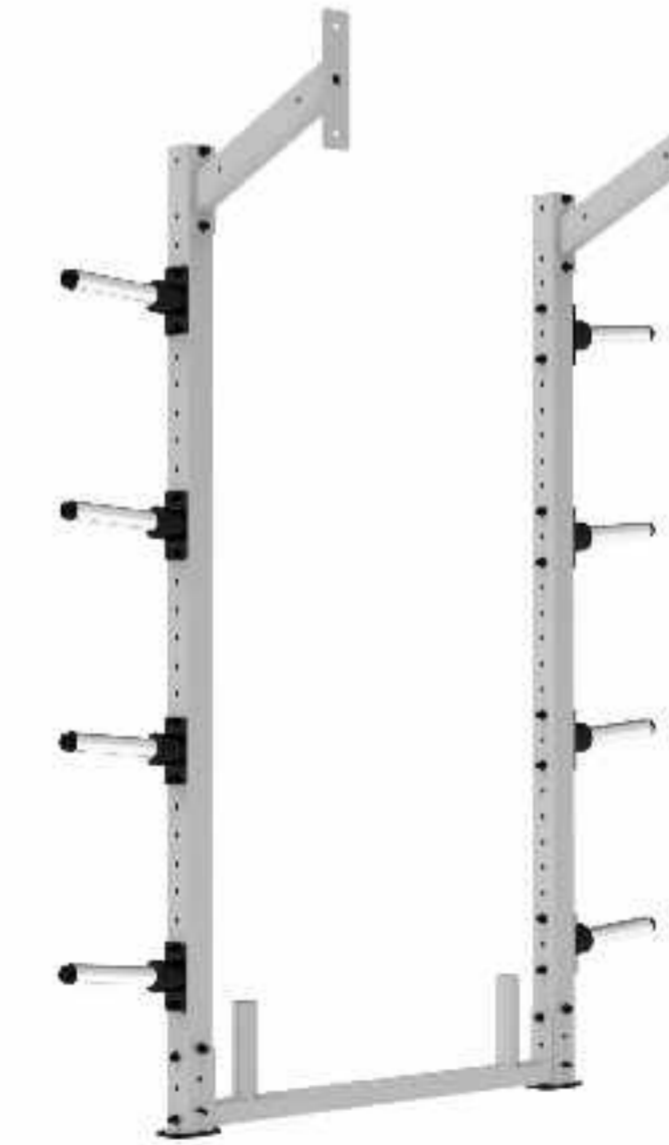

SE5011 STAND-SINGLE STORAGE

PRODUCT DIMENSION (L×W×H)	1842×563×2466(mm) 72.5×22.2×97.1 (in)
PRODUCT WEIGHT	64.4Kg



SE5012 COMBO STORAGE-SINGLE

PRODUCT DIMENSION (L×W×H)	1842×1031×2466(mm) 72.5×40.6×97.1 (in)
PRODUCT WEIGHT	73.4Kg



SE5021
RACK CONNECTOR-MULTI-GRIP

PRODUCT DIMENSION (L×W×H)	1900×225×230 (mm) 74.8×8.6×9.1 (in)
PRODUCT WEIGHT	19.5Kg



SE5022
RACK CONNECTOR-THICK STRAIGHT

PRODUCT DIMENSION (L×W×H)	1900×76×230 (mm) 74.8×3.0×9.1 (in)
PRODUCT WEIGHT	7.9Kg



SE5041 BAND PEGS

PRODUCT DIMENSION (L×W×H)	325×101×50 (mm) 12.8×4.0×2.0 (in)
PRODUCT WEIGHT	4.5Kg



SE5042 REVERSE J-HOOKS

PRODUCT DIMENSION (L×W×H)	252×95×250 (mm) 9.9×3.7×9.8 (in)
PRODUCT WEIGHT	13.7Kg



SE5043 SPOTTER STANDS

PRODUCT DIMENSION (L×W×H)	400×235×442 (mm) 15.7×9.3×17.4 (in)
PRODUCT WEIGHT	24.2Kg

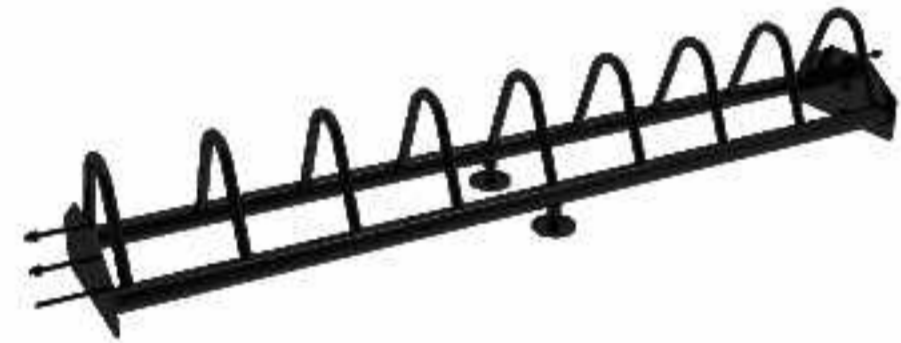

SE5023 BUMPER PLATE
STORAGE CONNECTOR

PRODUCT DIMENSION (L×W×H)	1900×76×230 (mm) 74.8×3.0×9.1 (in)
PRODUCT WEIGHT	24.4Kg



SE5024 FREE
STORAGE CONNECTOR

PRODUCT DIMENSION (L×W×H)	1900×432×171 (mm) 74.8×17.0×6.7 (in)
PRODUCT WEIGHT	36.5Kg



SE5025 BALL
STORAGE CONNECTOR

PRODUCT DIMENSION (L×W×H)	1900×280×260 (mm) 74.8×11.0×10.2 (in)
PRODUCT WEIGHT	14Kg



HZ7008
BATTLE ROPE ATTACHMENT

PRODUCT DIMENSION (L×W×H)	178×129×60 (mm) 7.0×5.1×2.4 (in)
---------------------------	-------------------------------------

*only for SE5002



HZ7009-01 STEP ATTACHMENT

PRODUCT DIMENSION (L×W×H)	773×661×338 (mm) 30.4×26.0×13.3 (in)
PRODUCT WEIGHT	16.3Kg(TBD)



SE5031 PLATFORM

PRODUCT DIMENSION (L×W×H)	2446×3421×50 (mm) 96.3×134.7×2.0 (in)
PRODUCT WEIGHT	263.5Kg

*only for SE5001



SE5032 PLATFORM

PRODUCT DIMENSION (L×W×H)	2446×4085×50 (mm) 96.3×160.8×2.0 (in)
PRODUCT WEIGHT	281.7Kg

*only for SE5002



HZ7010-01 DIP ATTACHMENT

PRODUCT DIMENSION (L×W×H)	946×625×339 (mm) 37.2×24.6×13.3 (in)
PRODUCT WEIGHT	12.6Kg(TBD)



HZ7012-01 PIVOT

PRODUCT DIMENSION (L×W×H)	530×126×289 (mm) 20.9×5.0×11.4 (in)
PRODUCT WEIGHT	5.9Kg(TBD)

*only for SE5002

HSP SERIES OF PROFESSIONAL PHYSICAL TRAINING EQUIPMENT

HSP professional physical training equipment is a perfect solution of multiple and customized functional training needs. It is designed to improve strength, endurance, speed, power, agility and dynamic balance. It can meet different requirements of professional athletes, sports teams, physical training center and big commercial gyms.

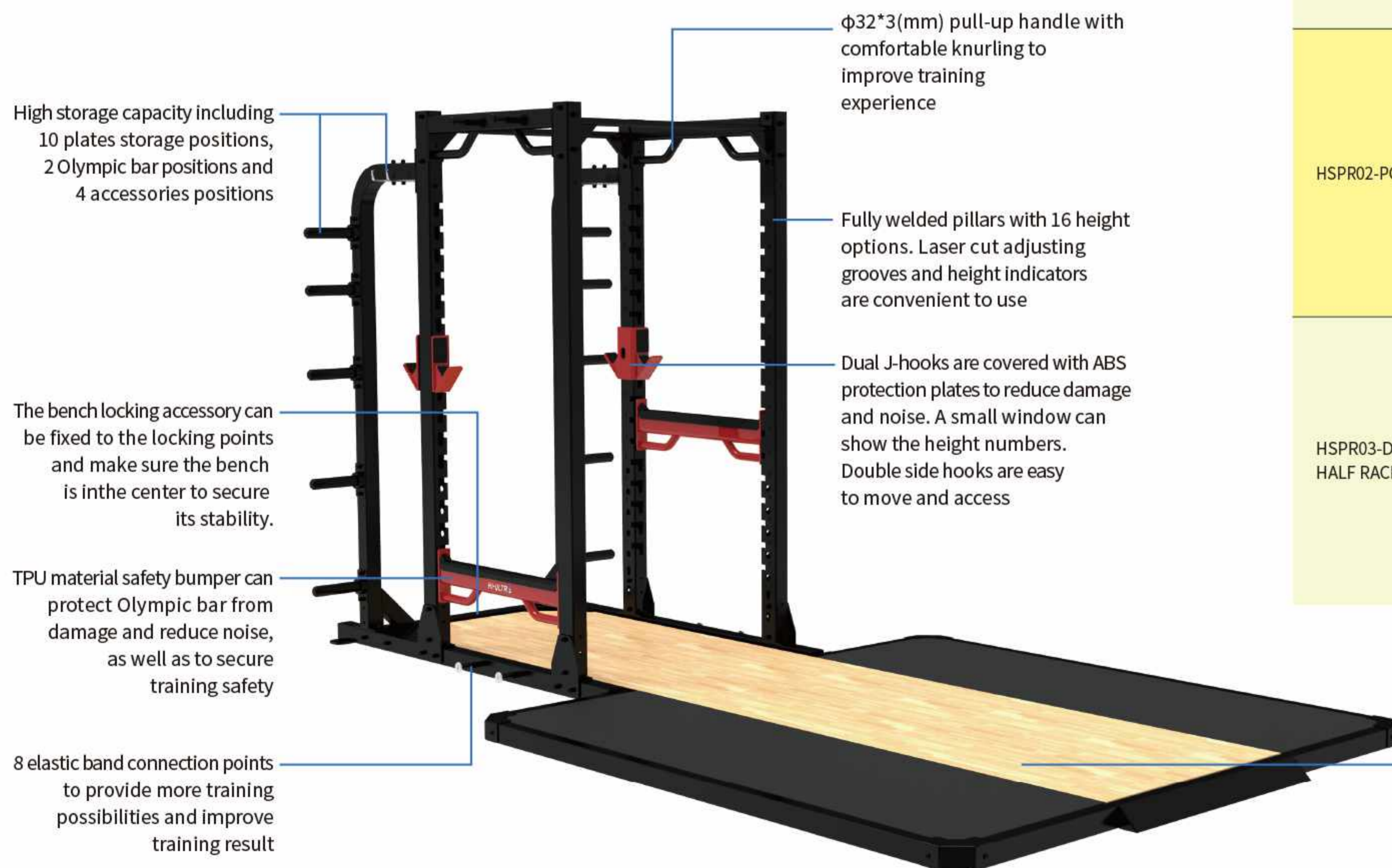

Shape		Optional Accessory Package	Product Dimension
HSPR01-HALF RACK		HSP7011 ADJUSTABLE DOCK' N LOCK BENCH HSPR21 RACK CONNECTOR-MULTI-GRIP HSPR31 PLATFORM(6FT*8FT) HSPR34 PLATFORM(8FT*8FT) HSPR41 STEP ATTACHMENT HSPR42 DIP ATTACHMENT HZ7008 BATTLE ROPE ATTACHMENT IZ7012 PIVOT SE5043 SPOTTER STANDS	1750×1470×2480(mm) 68.9×57.9×97.6(in)
HSPR02-POWER RACK		HSP7011 ADJUSTABLE DOCK' N LOCK BENCH HSPR21 RACK CONNECTOR-MULTI-GRIP HSPR32 PLATFORM(8FT*8FT) HSPR33 PLATFORM(6FT*8FT) HSPR41 STEP ATTACHMENT HSPR42 DIP ATTACHMENT HZ7008 BATTLE ROPE ATTACHMENT IZ7012 PIVOT SE5043 SPOTTER STANDS	2085×1750×2480(mm) 82.1×68.9×97.6(in)
HSPR03-DOUBLE HALF RACK		HSP7011 ADJUSTABLE DOCK' N LOCK BENCH HSPR21 RACK CONNECTOR-MULTI-GRIP HSPR31 PLATFORM(6FT*8FT) HSPR34 PLATFORM(8FT*8FT) HSPR41 STEP ATTACHMENT HSPR42 DIP ATTACHMENT HZ7008 BATTLE ROPE ATTACHMENT IZ7012 PIVOT SE5043 SPOTTER STANDS	2595×1750×2480(mm) 102.2×57.9×97.6(in)

Optional 76.2mm training platform has two sizes of 6ft x 8ft and 8ft x 8ft to fit different environments. Hardwood surface is anti-slippery so that higher friction can keep providing stable support. Thick rubber mat can absorb the impact to reduce noise and protect the floor



HSP7011
ADJUSTABLE DOCK' N LOCK BENCH

PRODUCT DIMENSION	1400×710×76.2 (mm) 55.1×28.0×3.0 (in)
PRODUCT WEIGHT	44kg(TBD)



HSPR21
RACK CONNECTOR-MULTI-GRIP

PRODUCT DIMENSION	2212×225×230 (mm) 87.1×8.9×9.1 (in)
PRODUCT WEIGHT	19.5kg(TBD)



HSP7013 GLUTE HAM BENCH

PRODUCT DIMENSION	1765×950×1400 (mm) 694.9×374.0×551.2 (in)
PRODUCT WEIGHT	70kg(TBD)



SL7040 SQUAT LUNGE

PRODUCT DIMENSION	1668×1669×636 (mm) 656.7×657.1×250.4 (in)
PRODUCT WEIGHT	130kg(TBD)



HSPR32 PLATFORM(8FT*8FT)

PRODUCT DIMENSION	4355×2560×76.2 (mm) 171.5×100.8×3.0 (in)
PRODUCT WEIGHT	263.5kg(TBD)



HSPR33 PLATFORM(6FT*8FT)

PRODUCT DIMENSION	3750×2560×76.2 (mm) 147.6×100.8×3.0 (in)
PRODUCT WEIGHT	263.5kg(TBD)



HSPR31 PLATFORM(6FT*8FT)

PRODUCT DIMENSION	3140×2560×76.2 (mm) 123.6×100.8×3.0 (in)
PRODUCT WEIGHT	263.5kg(TBD)



HSPR34 PLATFORM(8FT*8FT)

PRODUCT DIMENSION	3744×2560×76.2 (mm) 147.4×100.8×3.0 (in)
PRODUCT WEIGHT	263.5kg(TBD)



HSP7051 BUMPER
PLATE STORAGE CONNECTER

PRODUCT DIMENSION	1790×1310×1180 (mm) 704.7×515.7×464.6 (in)
PRODUCT WEIGHT	80kg(TBD)



HSP7052 HIGH ROW

PRODUCT DIMENSION	1875×1713×2123 (mm) 738.2×674.4×835.8 (in)
PRODUCT WEIGHT	160kg(TBD)



HSP7053 LEG CURL

PRODUCT DIMENSION	1705×620×742 (mm) 671.3×244.1×292.1 (in)
PRODUCT WEIGHT	40kg(TBD)



IZ7012
PIVOT

L.W.H	2850×1117×204 (mm) 112.2×44.0×8.0 (in)
N.W	38.3kg



HSPR41
STEP ATTACHMENT

L.W.H	798×661×338 (mm) 31.4×26.0×13.3 (in)
N.W	19.1kg(TBD)



HSPR42
DIP ATTACHMENT

L.W.H	985×626×260 (mm) 38.8×24.6×10.2 (in)
N.W	12.6kg(TBD)



SE5043
SPOTTER STANDS

L.W.H	400×235×442 (mm) 15.7×9.3×17.4 (in)
N.W	24.2kg



HZ7008 BATTLE
ROPE ATTACHMENT

L.W.H	178×129×60 (mm) 7.0×5.1×2.4 (in)
-------	-------------------------------------



ZONE360

Group Functional Training Solutions



H-ZONE



X-ZONE



I-ZONE



With years of experience in R&D and design, Impulse developed the brand new H-ZONE group functional station. It was developed on the concept of Modularity, Flexibility, Versatility and Space Efficient, which enables to make free combination between different station and attachments according to user demands and space requirements.



H-ZONE

HIIT Unlimited Combination Functional Training

It can make combinations of different stations and attachments according to the requirement of space.



Free Rotation



Enhanced Wall Connector

Space is an extremely valuable resource for the club. The three dimensional space design of the H-ZONE ensures the maximum use of space.

It breaks the limited space with infinite possibilities and creates more inspirations and possibilities for users.





Combination Example 1
HZ7002+HZ7004+HZ7002



Combination Example 3
HZ7002+HZ7004+HZ7003

Combination Example 2
HZ7002+HZ7004+HZ7001



Combination Example 4
HZ7003+HZ7004+HZ7001+HZ7004+HZ7002

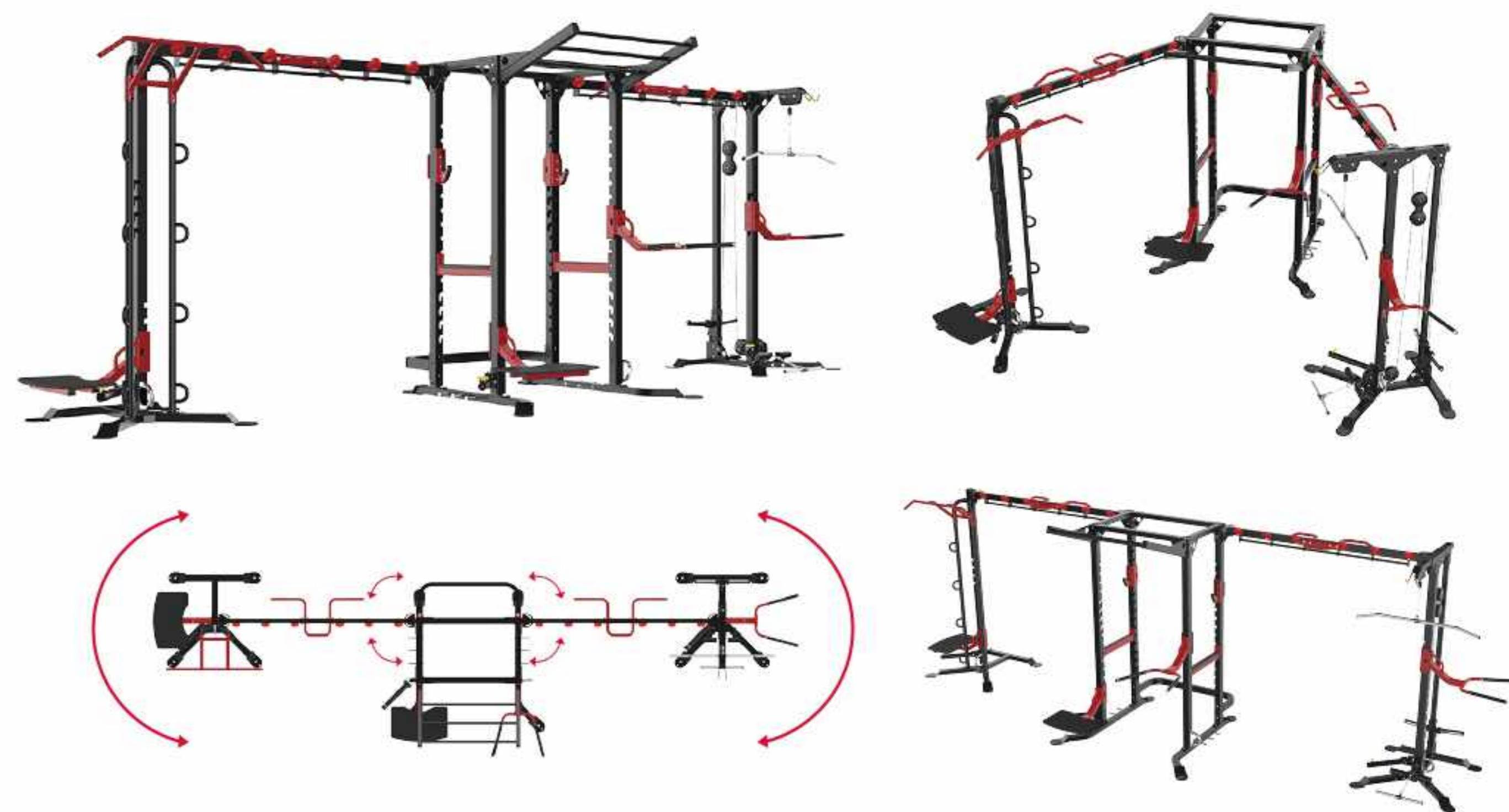



Combination Example 5
HZ7003+HZ7004+HZ7002+HZ7004+HZ7001

Combination Example 6
HZ7002+HZ7004+HZ7001+HZ7004+HZ7003+HZ7004+HZ7002

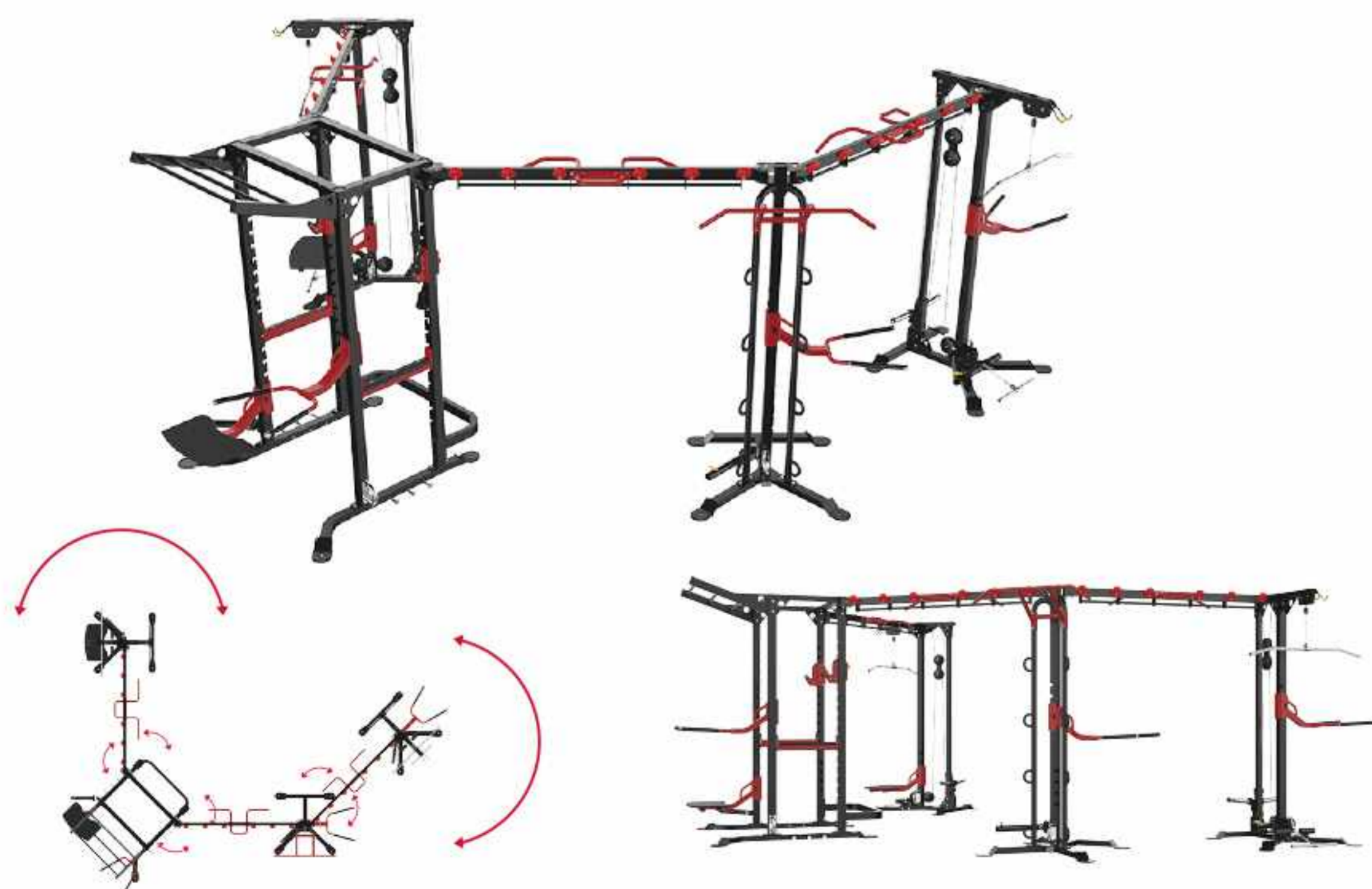

HZ7001
POWER RACK STATION

L.W.H	1373×1723×2558 (mm)
OPTIONAL	HZ7008 BATTLE ROPE ATTACHMENT
ACCESSORIES	HZ7009 STEP ATTACHMENT HZ7010 DIP ATTACHMENT IZ7012 PIVOT



HZ7002
HI-LOW PULLEY STATION

L.W.H	1106×1109×2413 (mm)
OPTIONAL	HZ7008 BATTLE ROPE ATTACHMENT
ACCESSORIES	HZ7009 STEP ATTACHMENT HZ7010 DIP ATTACHMENT IZ7012 PIVOT



HZ7003
MULTI-FUNCTION STATION

L.W.H	1142×1106×2411 (mm)
OPTIONAL	HZ7008 BATTLE ROPE ATTACHMENT
ACCESSORIES	HZ7009 STEP ATTACHMENT HZ7010 DIP ATTACHMENT IZ7012 PIVOT



HZ7001
MULTI-FUNCTION
CONNECTOR

L.W.H	2284×453×206 (mm)
OPTIONAL	TRX
ACCESSORIES	Climbing Pull-Up Bar



HZ7005
STORAGE CART

L.W.H	1362×535×1305 (mm)
-------	--------------------



HZ7006
WALL CONNECTOR

L.W.H	866×200×75 (mm)
-------	-----------------



HZ7008 BATTLE
ROPE ATTACHMENT

L.W.H	178×129×60 (mm) 7.0×5.1×2.4 (in)
-------	-------------------------------------



HZ7009-01 STEP
ATTACHMENT

L.W.H	773×661×338 (mm) 30.4×26.0×13.3 (in)
N.W	16.3Kg(TBD)



HZ7010-01
DIP ATTACHMENT

L.W.H	946×625×339 (mm) 37.2×24.6×13.3 (in)
N.W	12.6Kg(TBD)



HZ7012-01
PIVOT

L.W.H	530×126×289 (mm) 20.9×5.0×11.4 (in)
N.W	5.9Kg(TBD)









I-ZONE

Customized Group Functional Training

Impulse Zone offers modularized stations, and each station is interchangeable, which offers full customizability to best suit individual and group fitness needs to emphasize every aspect of functional strength, flexibility and endurance;

besides it is also the wonderful choice for clubs looking for cost and space saving while maximizing training options.



	Shape	Package	Product Dimension	Optional Accessory Package
IZ-S		IZ7001 Stretching Station IZ7003 Rebounder Station IZ7011 S-joint	3250×1120×2364(mm) 128×44.1×93.1(in)	IZ7009 Step Attachment IZ7010 DIP Attachment IZ7012 Pivot Kettlebell, Battle Rope, TRX, Medicine ball, Bar, Plate etc.
IZ-I		IZ7001 Stretching Station IZ7002 Boxing Station IZ7008 Stair-1	4794×1654×2446(mm) 188.7×65.1×96.3(in)	IZ7009 Step Attachment IZ7010 DIP Attachment IZ7012 Pivot Kettlebell, Punching Bag, Battle Rope, TRX, Medicine ball, Bar, Plate etc.
IZ-L		IZ7001 Stretching Station IZ7002 Boxing Station IZ7003 Rebounder Station IZ7008 Stair-1 IZ7011 S-joint	4794×3250×2446(mm) 188.7×128×96.3(in)	IZ7009 Step Attachment IZ7010 DIP Attachment IZ7012 Pivot Kettlebell, Punching Bag, Battle Rope, TRX, Medicine ball, Bar, Plate etc.
IZ-T		IZ7003 Rebounder Station IZ7004 Power Rack Station IZ7005 DAP Station IZ7006 Connector IZ7007 Stair-2	4694×3139×2446(mm) 184.8×123.6×96.3(in)	IZ7012 Pivot Kettlebell, Battle Rope, TRX, Medicine ball, Bar, Plate etc.
IZ-O		IZ7001 Stretching Station IZ7002 Boxing Station IZ7003 Rebounder Station IZ7005 DAP Station IZ7014 Stair-3	3637×3630×2446(mm) 141.3×136.7×96.3(in)	IZ7009 Step Attachment IZ7010 DIP Attachment IZ7012 Pivot Kettlebell, Punching Bag, Battle Rope, TRX, Medicine ball, Bar, Plate etc.
IZ-H		IZ7001 Stretching Station IZ7002 Boxing Station IZ7003 Rebounder Station IZ7005 DAP Station IZ7015 Stair-4	4137×2880×2449(mm) 162.9×113.4×96.4(in)	IZ7009 Step Attachment IZ7010 DIP Attachment IZ7012 Pivot Kettlebell, Punching Bag, Battle Rope, TRX, Medicine ball, Bar, Plate etc.
IZ-X		IZ7002 Boxing Station IZ7003 Rebounder Station IZ7004 Power Rack Station IZ7005 DAP Station IZ7006 Connector IZ7007 Stair-2×2	7489×3139×2446(mm) 294.8×123.6×96.3(in)	IZ7009 Step Attachment IZ7010 DIP Attachment IZ7012 Pivot Kettlebell, Punching Bag, Battle Rope, TRX, Medicine ball, Bar, Plate etc.



STRETCHING STATION

IZ7001

PRODUCT DIMENSION (L×W×H)	683×1655×2364 (mm) 26.9×65.2×93.1 (in)
PRODUCT WEIGHT	126.6 Kg / 279 Lbs
40'	57 Sets

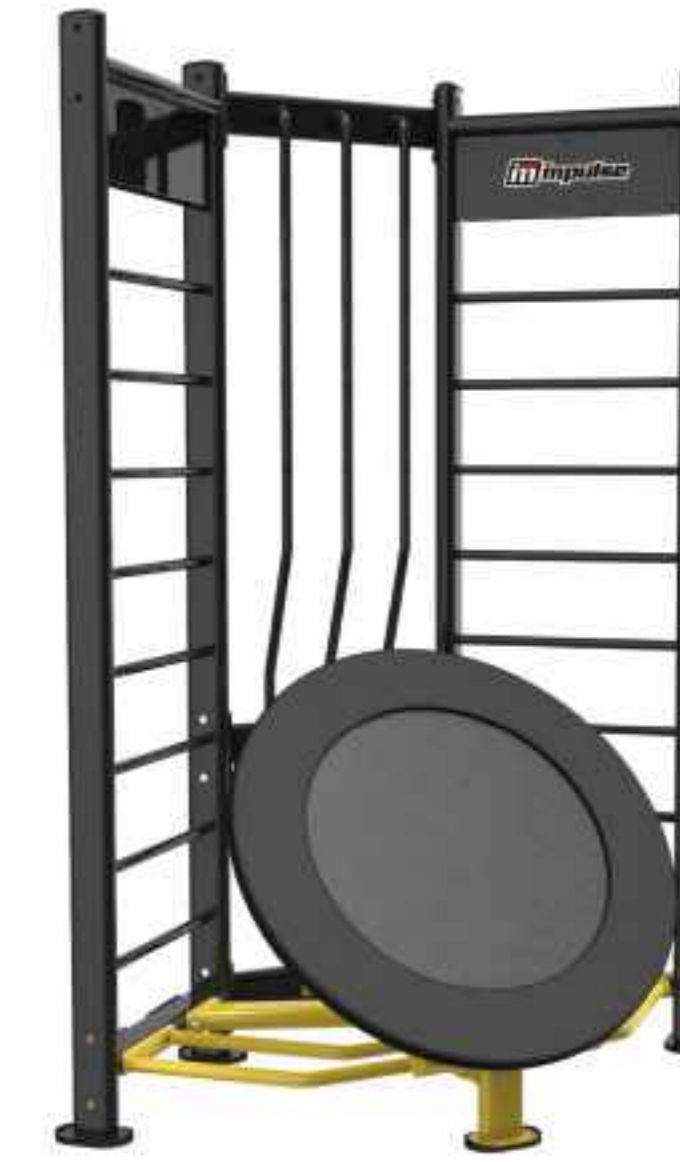

REBOUNDER STATION

IZ7003

PRODUCT DIMENSION (L×W×H)	1072×1655×2340 (mm) 42.2×65.2×92.1 (in)
PRODUCT WEIGHT	153.6 Kg / 339 Lbs
40'	61 Sets



POWER RACK STATION

IZ7004

PRODUCT DIMENSION (L×W×H)	1409×1747×2443 (mm) 55.5×68.8×96.2 (in)
PRODUCT WEIGHT	167 Kg / 368 Lbs
40'	120 Sets



BOXING STATION

IZ7002

PRODUCT DIMENSION (L×W×H)	1126×1655×2377 (mm) 43.3×65.2×93.6 (in)
PRODUCT WEIGHT	135.9 Kg / 300 Lbs
40'	57 Sets



DAP STATION

IZ7005

PRODUCT DIMENSION (L×W×H)	957×2386×2365 (mm) 37.7×93.9×93.1 (in)
PRODUCT WEIGHT	380.4 Kg / 839 Lbs
40'	56 Sets

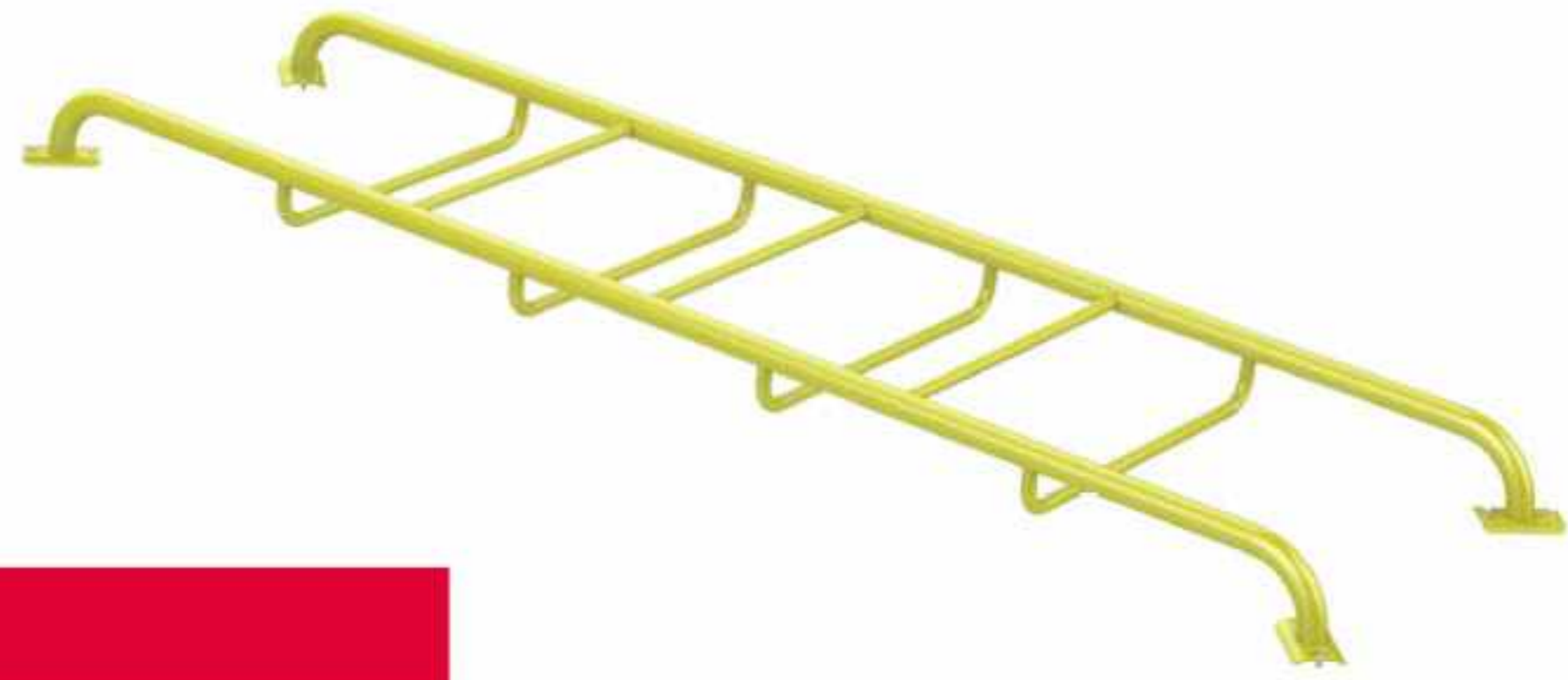

STAIR-1

IZ7008

PRODUCT DIMENSION (L×W×H)	3510×1010×205 (mm) 138.2×40×8.1 (in)
PRODUCT WEIGHT	43 Kg / 94.8 Lbs
40'	60 Sets



STAIR-3(for O-Shape)

IZ7014

PRODUCT DIMENSION (L×W×H)	2435×1207×205 (mm) 95.9×47.5×8 (in)
PRODUCT WEIGHT	35.6 Kg / 78.5 Lbs



CONNECTOR

IZ7006

PRODUCT DIMENSION (L×W×H)	1528×178×205 (mm) 60.2×7×8.1 (in)
PRODUCT WEIGHT	13.9 Kg / 30.6 Lbs
40'	660 Sets



STAIR-4(for H-Shape)

IZ7015

PRODUCT DIMENSION (L×W×H)	2406×1704×205 (mm) 94.7×67.1×8 (in)
PRODUCT WEIGHT	35.6 Kg / 78.5 Lbs

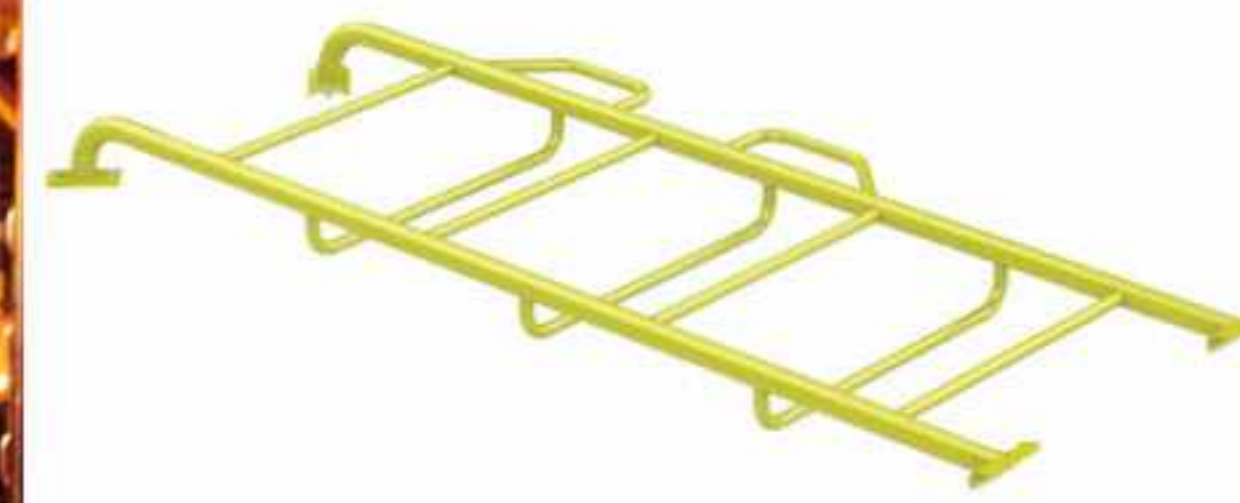
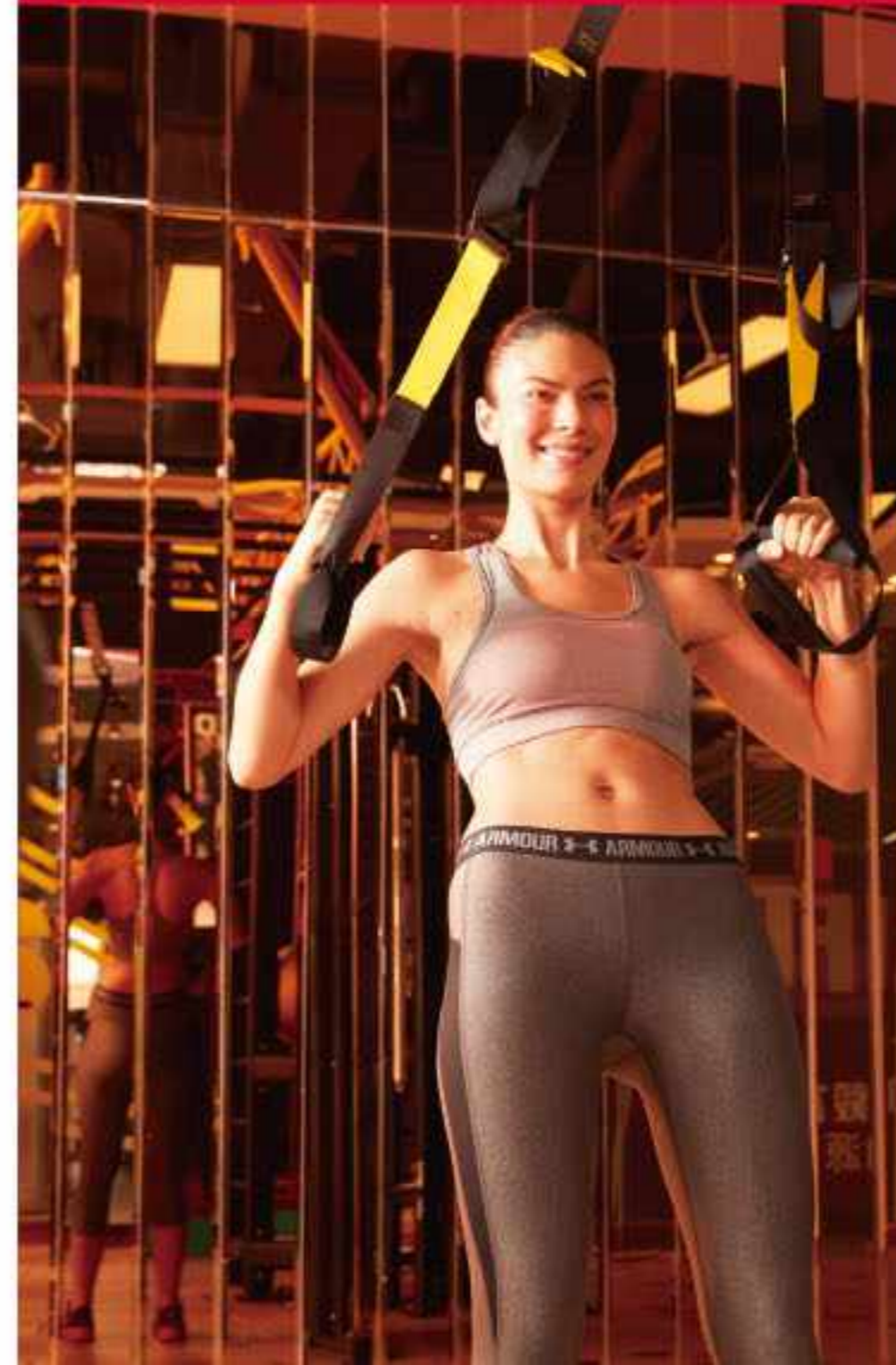

STAIR-2

IZ7007

PRODUCT DIMENSION (L×W×H)	2850×1117×204 (mm) 112.2×44×8 (in)
PRODUCT WEIGHT	38.3 Kg / 84.5 Lbs
40'	78 Sets



PIVOT

IZ7012

PRODUCT DIMENSION (L×W×H)	530.5×126×178 (mm) 20.9×5×7 (in)
PRODUCT WEIGHT	5.9 Kg / 13 Lbs
40'	5083 Sets

DIP ATTACHMENT

IZ7010

PRODUCT DIMENSION (L×W×H)	940×624×289 (mm) 37×24.6×11.4 (in)
PRODUCT WEIGHT	12.6 Kg / 28 Lbs
40'	245 Sets



S-JOINT

IZ7011

PRODUCT DIMENSION (L×W×H)	178×100×50 (mm) 7×3.9×2 (in)
PRODUCT WEIGHT	2.6 Kg / 5.7 Lbs
40'	13066 Sets



STEP ATTACHMENT

IZ7009

PRODUCT DIMENSION (L×W×H)	749×650×289 (mm) 29.5×25.6×11.4 (in)
PRODUCT WEIGHT	16.3 Kg / 36 Lbs
40'	315 Sets





X-ZONE

Elite Group Functional Training Stations

X-zone is advanced and functional group training system which developed and updated from “H” shaped station of I-Zone.

- **Advancements:** integrated with Crossfit training method that can improve physical strength, explosive, speed, coordination and flexibility with X-zone.
- **Comprehensiveness:** X-zone can suit for beginner to advanced trainers and improve training effect in all directions
- **Efficiency:** maximize the value of indoor space through delicate structure design.

Place 5 advanced station on X-Zone training station

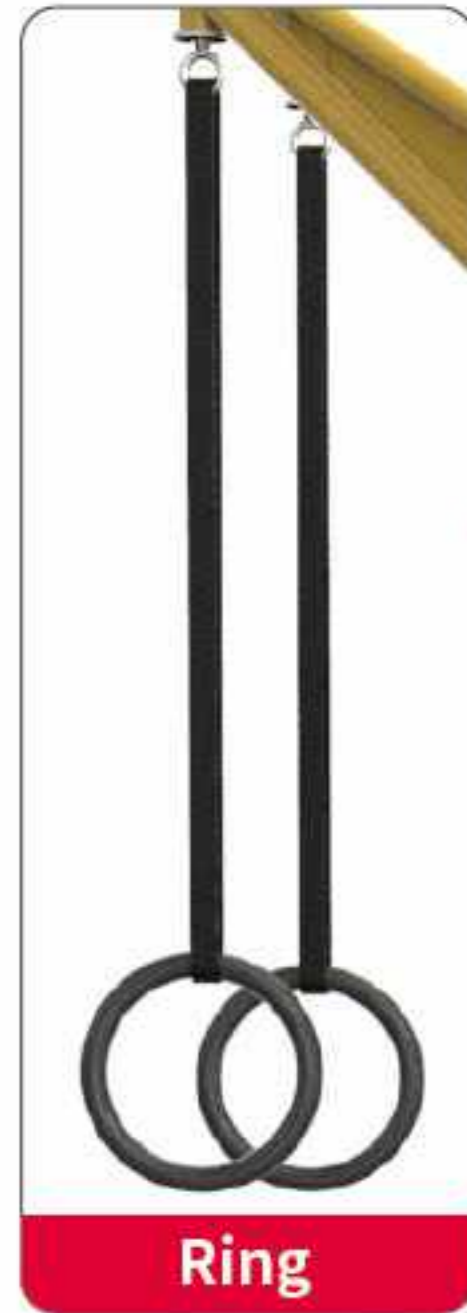

Ring



Climbing Rope

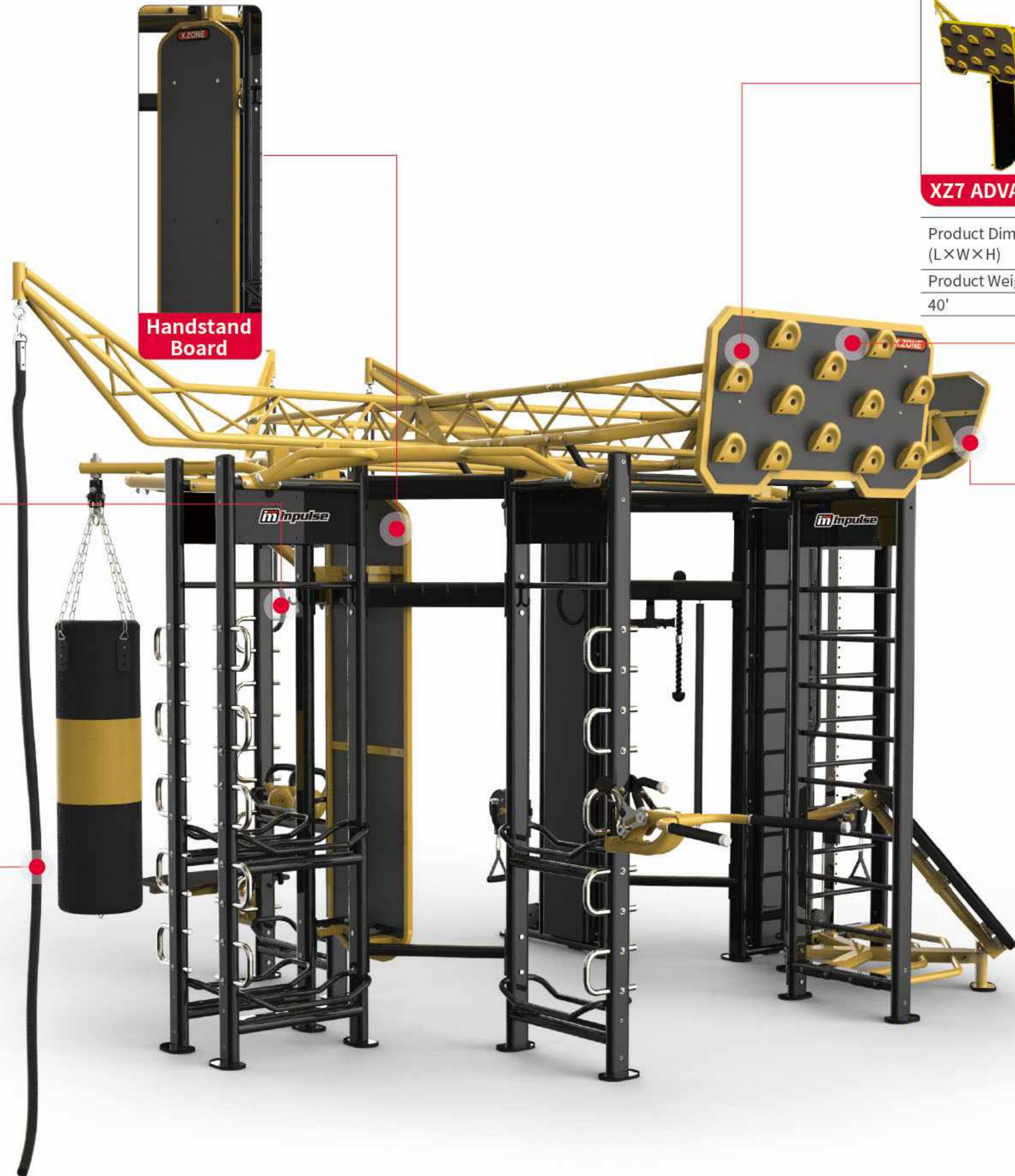

Handstand Board



XZ7 ADVANCED TRAINING FRAME

Product Dimension (L×W×H)	5150×3570×2650(mm) 202.8×140.6×104.3(in)
Product Weight	229.5kg/504.9lbs
40'	24



Climbing



Wall Ball

Package-1	IZ7001 Stretching Station IZ7002 Boxing Station IZ7003 Rebounder Station IZ7005 DAP Station
Package-2	XZ7 Advanced Training Frame: Climbing Handstand Board Wall Ball
Assembly Size	5150x3570x3010(mm)
Optional Accessory Package	IZ7009 Step Attachment IZ7010 DIP Attachment IZ7012 Pivot XZ5001 ring XZ5002 climbing rope XZ5003 wall ball, Punching Bag, Kettlebell, Battle Rope TRX, Medicine Ball, Bar Plate, etc.



CASES



CASES



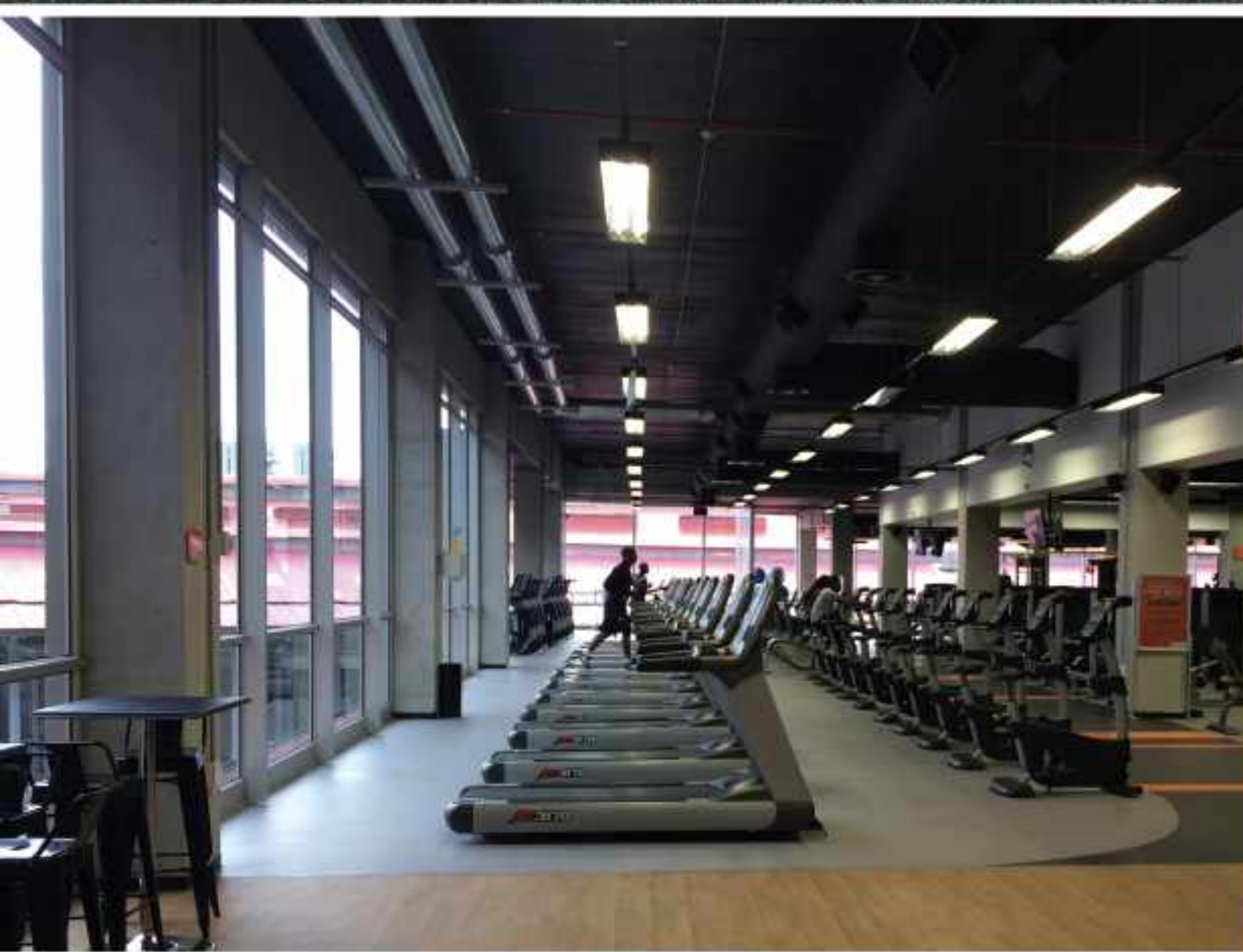



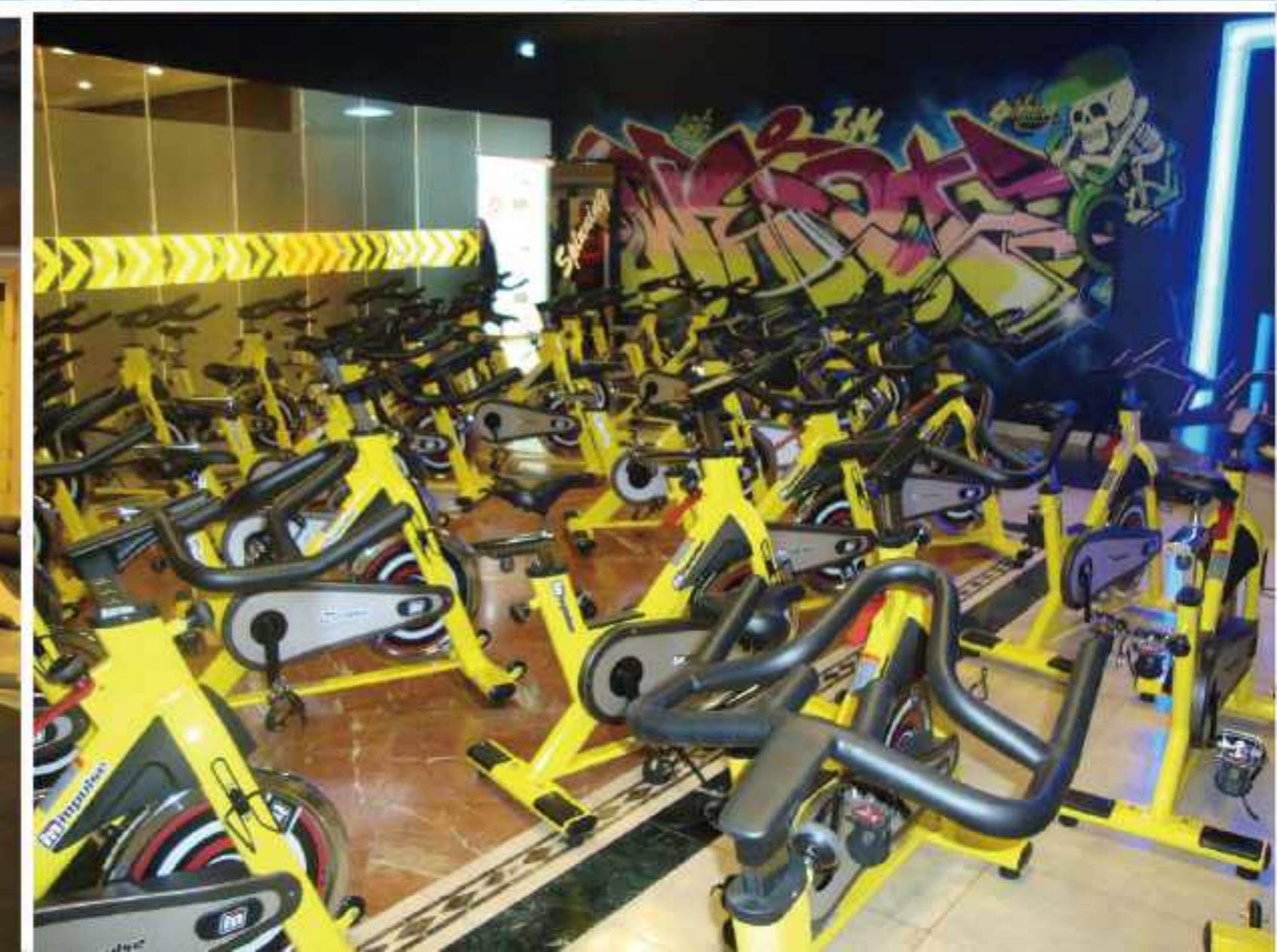
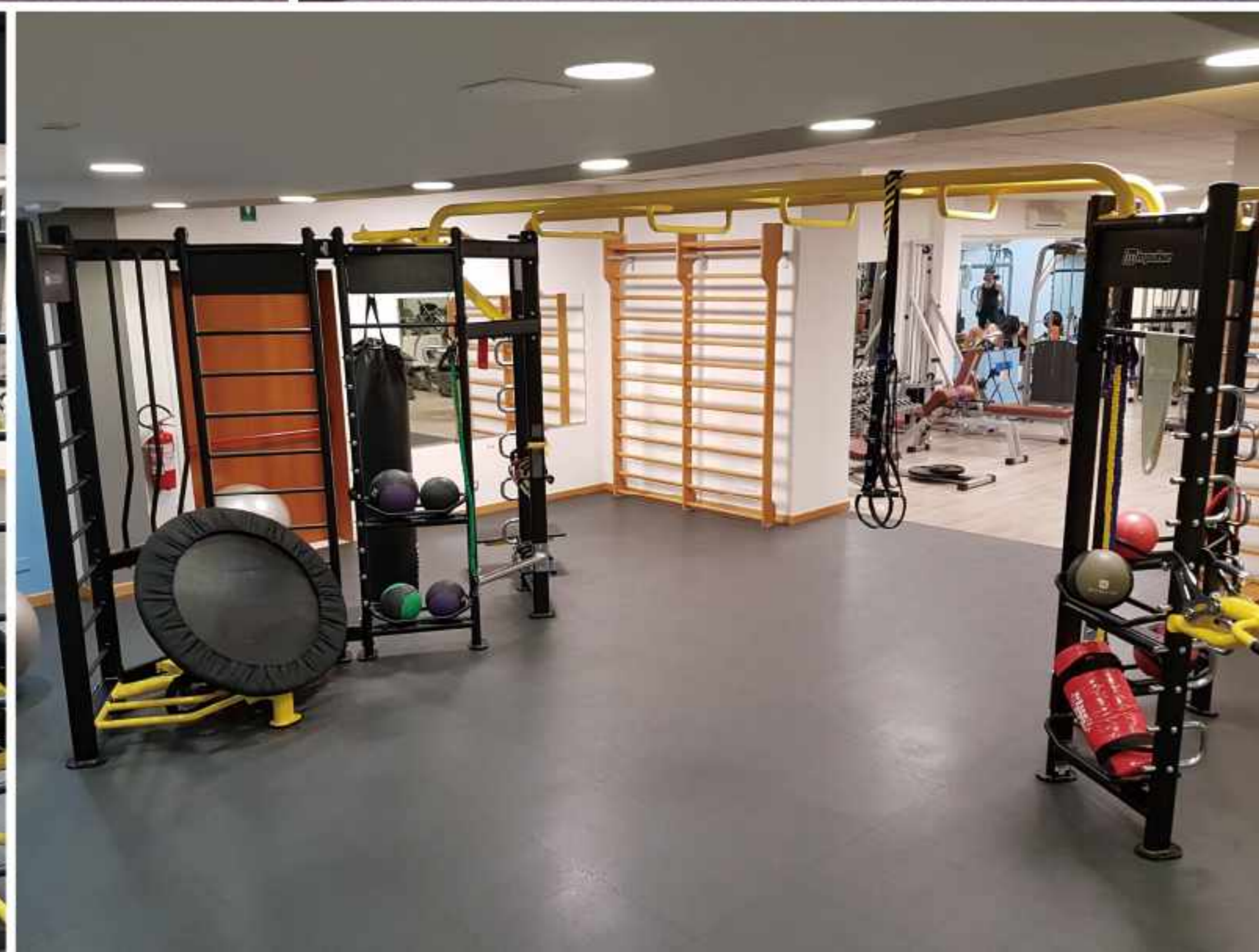



CASES

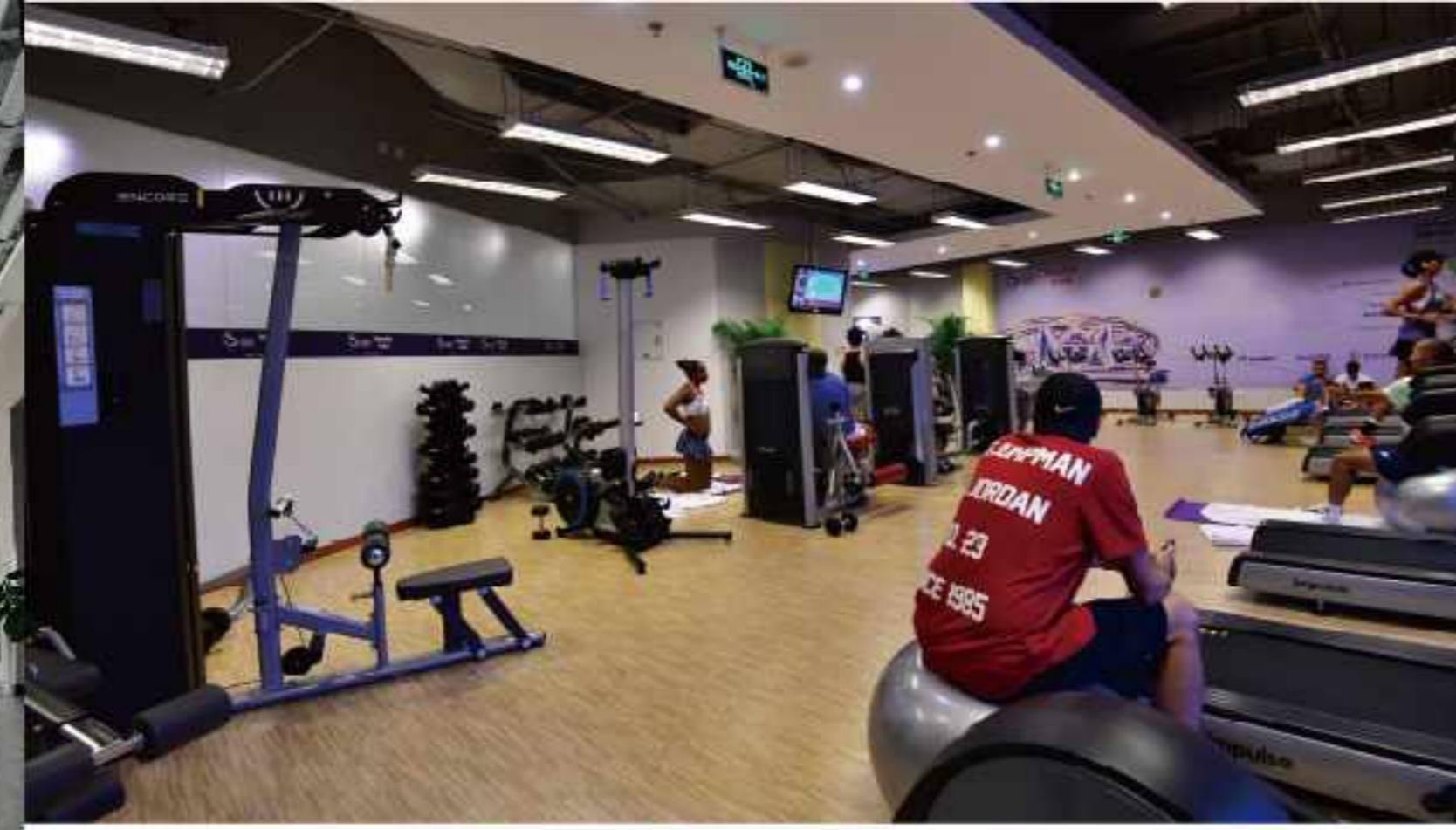

CASES





Impulse Cardiovascular Equipment Limited Warranty

Description	Warranty
Frame	7 Years
Treadmill AC Motor	3 Years
Treadmill DC Motor, Structural Moving Parts	2 Years
Display PCB, Motor Controller, Generator, EMS, ECB Brake	2 Years
Key Pad, Durable Wear Parts	1 Year

Impulse Strength Training Equipment Limited Warranty

Description	Warranty
Structural Steel Frame	Lifetime
Rotary Bearings, Weight Stacks, Pulleys, Guide Rods, Structural Moving Parts	2 Years
Cable, Linear Bearings, Springs	1 Year
Upholstery, Handgrips, All Other Items Not Listed	6 Months

* Conditions and Restrictions Applied.



im *impulse*

THE WAY TO WELLNESS

All text, picture and data in this catalogue are for reference only. If there is inconsistency between the information and the actual product, the actual product shall govern. Impulse reserves all rights to explain any error or difference in this catalogue.

Statement: Impulse branding is upgrading and during that time, **im** *impulse* and *impulse* are both trademarks of Impulse products. Thank you for your support as always.